

Section 2

Barnett	2-4,7
Cables	12-14
Clutch Hubs	10-11,40-43
Clutch Parts	2-11
Alto	5
BDL	6-7
Barnett	2-4
Rivera	5
York	8
Delkron	45
5 Speed Clutch BT	40-44
5 Speed Trans Parts BT ...	30-35,53-54
6 Speed BT.....	55-56
Kicker, BT 5 Speed	49-51
Pulleys	28-29
Rotary Top	18
Shifter BT	18-27,35-37
Shift Kits	19
Shift Levers	22-24,27
Sprocket Covers, XL	57
S&S Transmission Casing	45-46,56
XL Clutch	10-11
XL Shifter Parts	60-62
XL Trans	58-61

Clutch

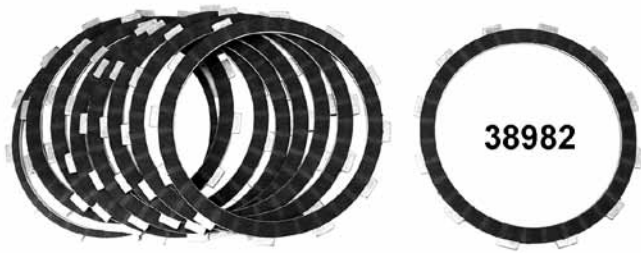

Barnett Series K Friction Plates

Kevlar Clutch Plates are the ultimate in durability, smoothness, and strength. The alloy backed plates give smooth precise launches and shifting even under extreme heat. 100% asbestos free.

PCP Model

- 38972** XL 1984-90
- 38979** As above w/extra plate
- 38976** BT Evo 1984-89
- 38977** BT 1990-97, XL 91-10
- 38978** As above with extra plate
- 38982** BT 1998-99, TC-88 1999-10
- 38988** As above with extra plate

***Note: Models noted with extra plates (EPK's) have one more plate for 20% more surface.**

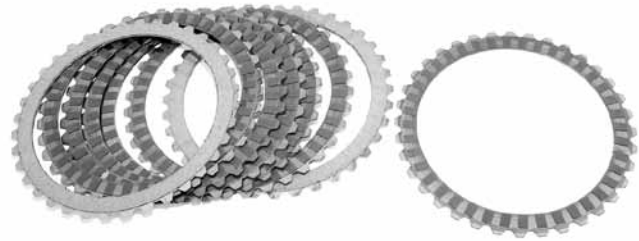

BarnettCF 2000 Carbon Fibre Segmented Plates-Wet

New friction material segments increasing efficiency and plate life. Segmented plates run 25% cooler and torque load is increased by 20%. Compatible with stock steel plates, springs and all oils.

PCP Application

- 38932** XL 1984-90
- 38933** XL 1991-10, BT 1990-97
- 38934** As above, extra plate kit
- 38935** BT 1984-90
- 38937** BT 1998-10 including Twin Cam

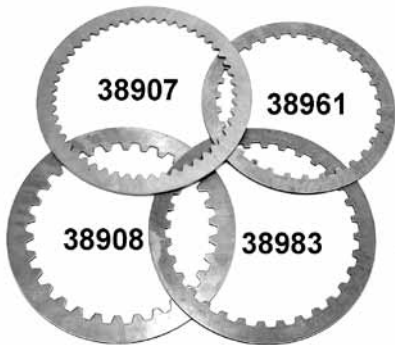

Barnett Stock Replacement Drive Plates 1984-on (each)

Steel drive plate to fit BT & XL with diaphragm clutch.

PCP Fits

- 38961** BT 1990-97, XL's 1991-10 (need 6) (37975-90)
- 38983** BT 1998-99, TC-88 1999-10 (need 8) (37913-98)
- 38907** BT 1984-89 (need 7) (37975-84)
- 38908** XL 1984-90 (36787-84)



Barnett Carbon Graphic Clutch Kit

Kit includes complete set of carbon graphite frictions and steels for use in dry clutch conversions.

- 38966** BT 1984-89 (6 plates, 7 steels)
- 38967** BT 1990-97 and XL 1991-10 (9 plates, 8 steels)

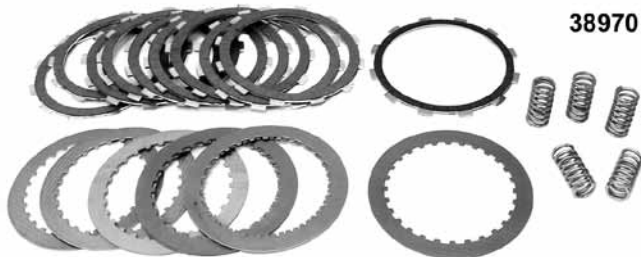

Barnett V-Rod Clutch Plate Kit

- 38969** Clutch kit
- 38970** Extra plate kit

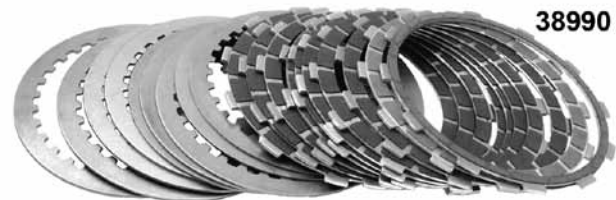

Barnett 1998-10 BT, TC Clutch Kits

PCP Description

- 38989** 9 Friction and 8 steel plates
- 38990** Carbon fiber extra plate kit with 10 friction and 9 steel plates

Clutch



Barnett Scorpion Clutch Drive

Kit features over twice as much friction surface area compared to stock clutch. All Scorpion clutches provide a positive engagement and release. Scorpion clutches incorporate 6 heavy duty coil springs. In addition, an extra spring set with a different spring rate is included which allows the clutch to be tuned for street or race application depending on usage. Tunability is easy without the removal of the primary cover. Barnett friction plates are compatible with any primary oil. Each kit is designed to be used with stock type clutch basket.

Big Twin (except 06 Dyna)

PCP Application

38944	1986-89
38945	1990-97
38946	1998-06



Sportster

38941	1984-90 4 speed Evo
38942	1991-on 5 speed Evo



Barnett Scorpion Lock-Up Pressure Plate

For use on existing Scorpion clutches. Must be used with open primary or Scorpion primary cover.

38951 1998-06 All models except 2006 Dyna



Barnett Scorpion Clutch Assemblies

Increases clutch surface area by 100%. Features six coil springs, steel inner hub, and billet aluminum pressure plate. Extra spring sets are included for multiple spring pressure options. Designed to fit into OEM type clutch basket.

PCP Description

38948	2006-07 Dyna
38949	1999-06 Touring models and 2000-06 Softails using HD hydraulic system



Barnett Scorpion Clutch Assembly for H.D. Hydraulic System

Fits 1999-06 late Touring models and 2000-06 late Softail models. Does not fit FXSTB/I and FXSTD/I.

38939



Barnett Scorpion Lock-Up Clutch

Features a billet aluminum pressure plate with six adjustable pressure arms that increase clutch pressure as RPMs increase. Suitable for 200+ HP motors. Must be used with open primary or Scorpion primary cover.

38950 1998-06 All models except 2006 Dyna

Clutch



Barnett Heavy-Duty Clutch Spring

Heavy-duty replacement clutch spring for Big Twins 1984-on and Sportsters 1985-on. 20% stronger than stock and suitable for street applications.

- 38917** 1984-89 Big Twin (37902-84A)
- 38920** 1984-90 Sportster (36792-84)
- 38919** 1990-97 Big Twin & 1991-10 Sportster heavy duty As above, standard duty (37871-90)
- 38984** 1998-99 BT, 1999-10 TC-88 standard (37871-98)
- 38985** As above heavy-duty
- 38866** Alto standard 1998-08 BT and TC (37871-98)

S&S High Performance Clutch 1991-06

Clutch includes 10 steel plates and 11 friction plates with narrow bands of friction material. These narrower bands offer improved gripping power and an increased friction diameter centreline. With the centreline farther away from the centre of the clutch, more leverage to turn the transmission is produced. The S&S clutch is able to handle 150 horsepower with clutch lever effort that is slightly less than a stock clutch. A stronger pressure plate spring is available for competition type applications that will increase the power handling ability to almost 200 horsepower. An early style 66T ring gear is supplied because the stronger teeth are better able to stand up to the forces required for big inch engines. An early style starter pinion gear is required for all 1994-05 models. The S&S performance clutch is slightly larger than stock and can be used in stock primary cases with minor clearancing, which is not visible when the primary is assembled. Suitable for use with S&S 6 speed transmissions.

PCP Application

- 565150** Clutch with 36T chain sprocket (not 06 Dyna)
- 565151** Clutch with 37T chain sprocket (not 06 Dyna)
- 561037** 9T Starter pinion gear
- 565106** High pressure competition clutch springs
- 565109** Low pressure Touring clutch springs



Barnett Clutch Spring Conversion

Billet pressure plates eliminate diaphragm spring and allows use of coiled spring for more tuneability and more positive linear clutch action.

- 38986** Twin Cam 1998-on
- 38987** BT L1984-89

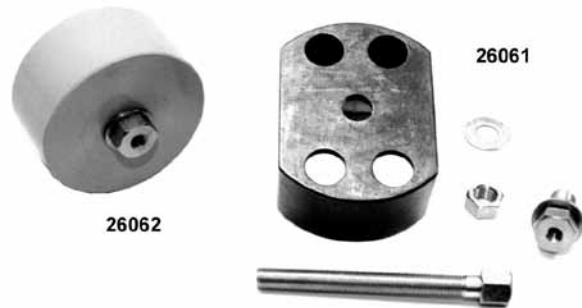

Barnett Clutch Tool For Evo's

Diaphragm clutch spring compression tools make it easier to remove and re-install retainer ring.

- 26061** 1990-99 BT and 1991-99 Sportsters
- 26062** 1984-90 Sportsters

Clutch



Alto Clutch Kits

Alto clutch products are manufactured in the USA of friction grabbing clutch material. These kits have two sided fibre plates, bonded on steel, for applications listed. Sold in sets.

PCP	Year	Model
38871	1984-90	Sportster (7)
38872	1991-on	Sportster (8)
38875	1984-89	Big Twin (6)
38872	1990-97	Big Twin (8)
38876	1998-10	Big Twin (9) Red Eagle
38877	1998-10	Big Twin (9) Kevlar

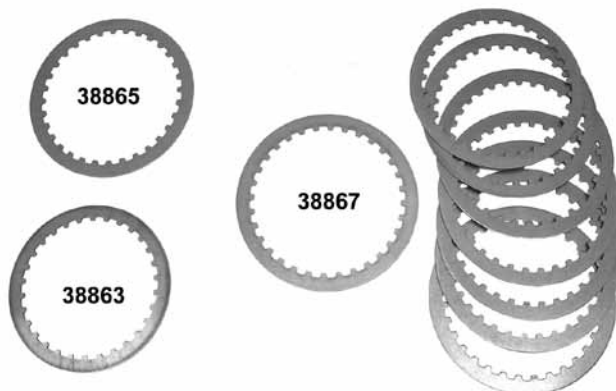

Rivera Pro-Clutch

Converts old style clutch packs to smooth diaphragm spring function. Available for chain with wet or dry clutch. Kits include clutch hub with bearings, clutch discs (friction and steel), diaphragm spring, spring retainer, pressure plate and 4 shoulder bolts. 1984-on kits use existing clutch basket and include a hub which allows the use of clutch plates that increase surface area by 100% to reduce slipping.

PCP	Clutch Basket Type
76137	1986-89 Chain BT
76138	1990-97 Chain BT
76139	1998-06 Chain BT
76140	2006-on Dyna and 2007-on BT
76141	1991-10 Chain XL

Replacement Friction & Steel Sets

59611	1984-89 Chain for #76137
76084	1990-97 Chain for #76138
76085	1998-on Chain for #76139
76083	1991-10 Chain for #76141

Alto Steel Drive Plates

Steel drive plates by Alto Products Corp. are made in the USA for models listed. (Sold each).

PCP	Year	Model	# Required
38861	1984-89	Big Twin	(7)
38863	1990-97	Big Twin	(6)
38865	1998-10	Big Twin (37913-98)	(8)
38867	1998-10	BT 8 piece kit	

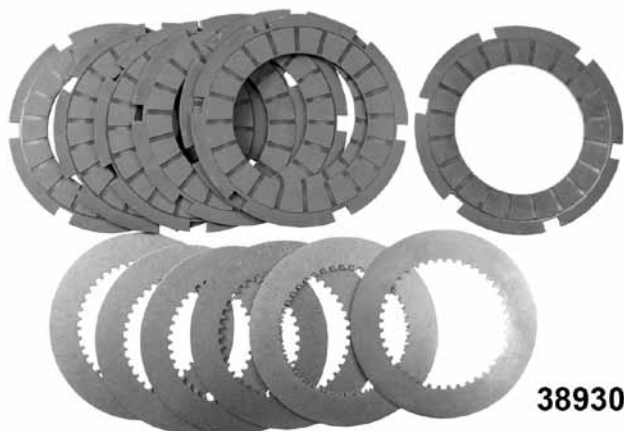

Rivera-Primo Replacement Clutch Kits from Barnett

PCP	Fitment
38929	1936-84 Pro Clutch belt drive
38930	1936-84 Pro Clutch chain drive
38938	1986-99 BT Evo Pro Clutch

Easy Clutch Kit for Twin Cam

This kit features a clutch spring and inner/outer ramps that significantly reduce the effort required to use the clutch lever. Fits 1999-05 Twin Cam models (stock on 2006-on) but is not compatible with screamin eagle performance parts.

29030	T/L
59916	Preston

Clutch

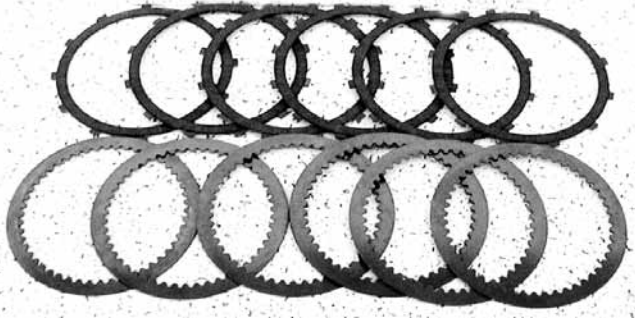

BDL Clutch Kits

BDL Clutch kits feature kevlar friction plates, steel plates and high pro diaphragm springs when required.

PCP	Fits	# of Plates Included		
		Kevlar	Steel	Spring
76461	BT 1984-89	6	7	None
76464	BT 1998-01	9	8	None
76462*	BT 1990-97	8	6	1
	XL 1991-on			
76463	BT 1990-97	9	8	1
	XL 1991-on			

*Note: Must re-use stock double riveted steel plate.

All **BDL clutch kits** are made of either 6062 T6 or high tempered steel with Kevlar material. Each plate design was tested so maximum performance is achieved. Different groove patterns were designed for maximum oil circulation and heat dissipation. The steady flow of lubricant will cool and determine the longevity of your clutch. All BT kits are packaged with frictions and steels and a pre-measured stack height for easy installation.



BDL Ultimate Clutch Kit

This high performance clutch lets you choose between a diaphragm or coil spring application. Kit will fit any BDL belt drive open or closed. Kit includes 2 diaphragm springs, spring collar, 12 springs and shoulder bolts.

76505

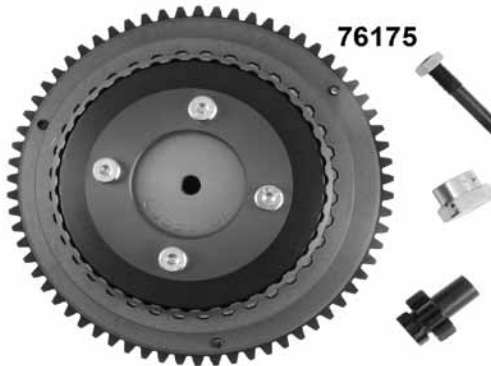

BDL Chain Drive with Ball Bearing Lock Up Clutch for 1998-06 Big Twin Models

Ball bearing clutch basket features a pressure plate that uses 5/16" steel ball bearings, diaphragm, retainer and adjusting screw. For larger engines it may be necessary to use carbide balls.

PCP	Description
76175	Complete clutch basket (less chain) (CDB-2-90)
76176	Clutch basket and chain kit includes complete clutch basket, adjuster shoe with bracket, Diamond primary chain and 25T front sprocket (CDB-1-90)
76177	Clutch basket and compensator kit includes complete clutch basket, adjuster shoe with bracket, Diamond primary chain, 25T front sprocket and BDL compensator (CDBCS-1-90)

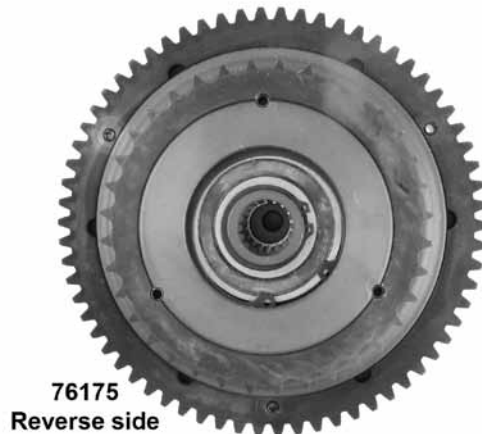

Clutch

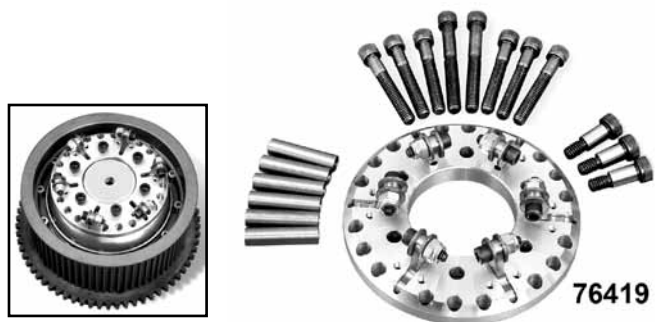

BDL Lock-Up Clutch Kit

Designed to fit all EVO and EVB style belt drives. Centrifugal force allows the actuator arms to move outward, which applies extra pressure against the pressure plate and clutch springs for positive engagement with no clutch slippage.

76419 (LUC-100)

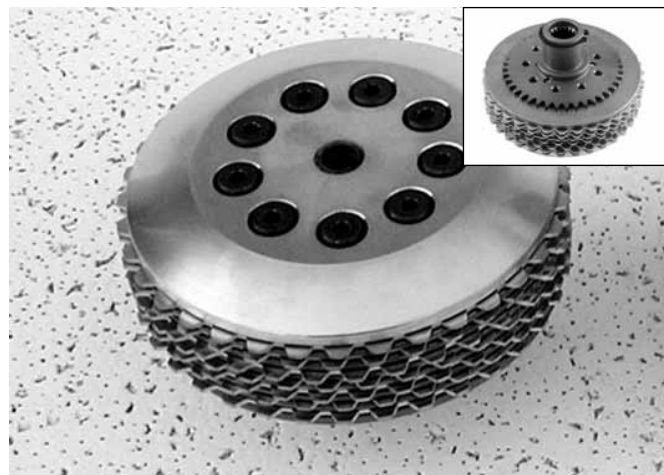

BDL Competitor Clutch Kit

Kit includes 40mm double row hub bearing, polished pressure plate, Kevlar clutch and 9 springs and shoulder bolts for simple adjustment.

PCP Item

76421 BT w/chain primary drive 1990-97

76449 7 fibre plates for #76421

76450 8 steel plates for #76421

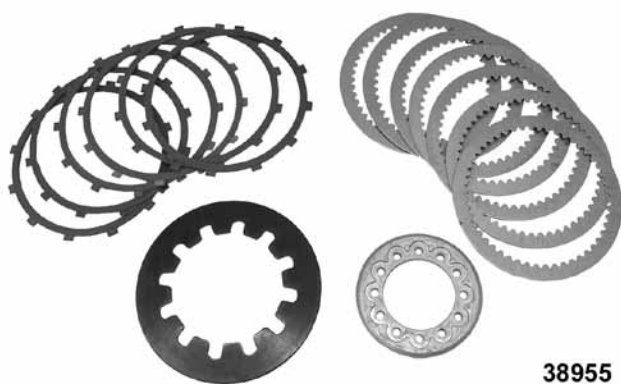
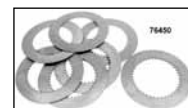

38955

BT Clutch Pak Kit

Complete, heavy duty OEM style clutch kit includes bonded to steel clutch Kevlar friction and 4 steel plates, clutch hub liner with rivets and 10 springs. 1985-97 types include friction plates, steel plates and diaphragm spring.

PCP Type Application

38955 Wet Red Eagle type 1985-89

38956 Wet Red Eagle type 1990-97



BDL Ball Bearing Competitor Clutch

Fits Harley stock clutch baskets 1998 to 2006. Ball bearing lock-up pressure plate will handle large inch motors. 60% More clutch surface than stock, makes clutch slippage a thing of the past.

76300



#76300 Replacement Components			
A	76236	Pressure plate	G 76188 Clutch adjusting screw w/nut
B	76237	5/16" Ball bearings (42 pk)	H 76239 .120 Steel
C	76220	Diaphragm spring	J 76240 Kevlar fibers (7 pk)
D	76238	Clutch hub	K 76241 .059" Steels (6 pk)
E	76221	Spring retainer	
F	76242	3/8 x 7/8 Shoulder bolts (4)	

Clutch

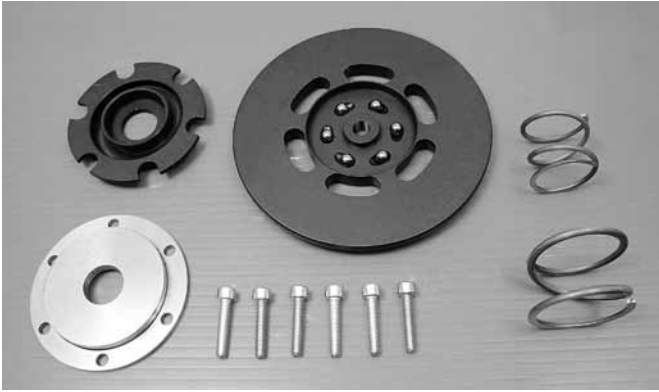

York Pressure Plate

Fits 1998-on BT featuring positive engaging ball ramp activation.

38009

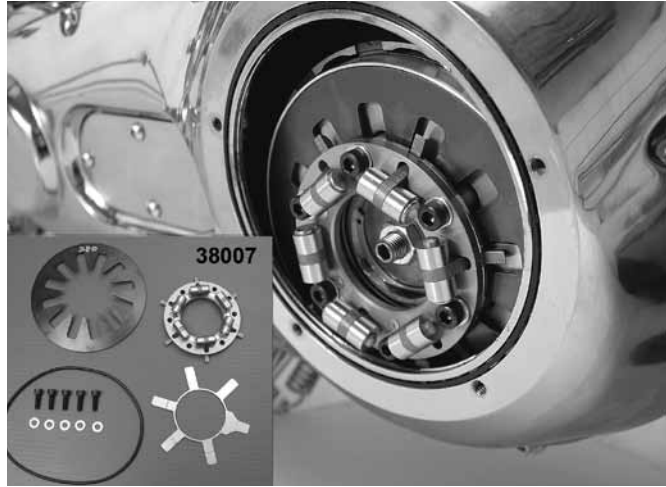

Variable Spring Clutch Combo

Includes spring with an initial pressure of 285 lbs, and progressively reduces pressure to 215 lbs as the lever is pulled. This is a 30% lever pull reduction over the stock components for 1998-05 BT models. Variable pressure clutch features:

- stronger clutch engagement than stock as revs increase
- acts like a lock-up clutch

-35-40% reduction in effort at the clutch handle when measured at idle

PCP Year

38007	6
38008	12

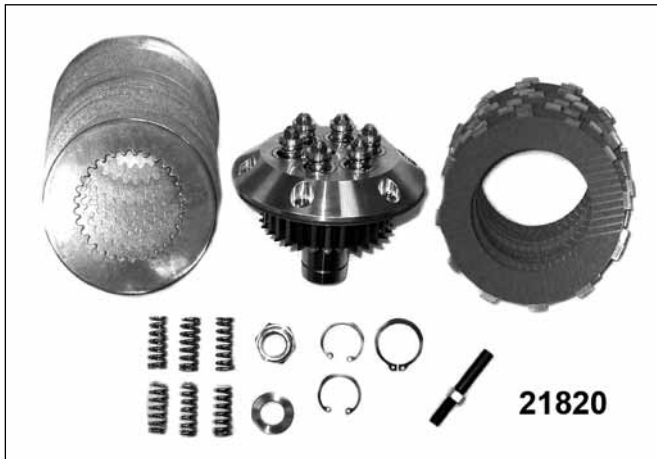
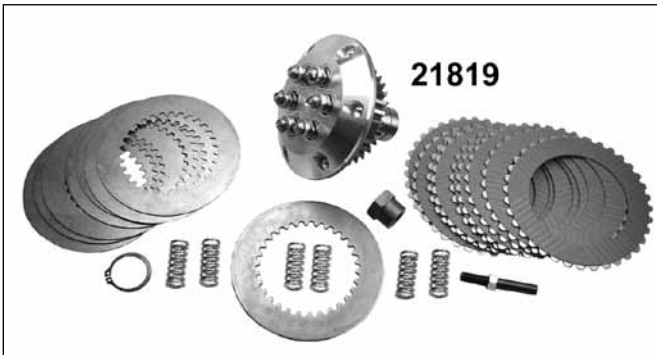

York Hi Performance

Designed for better clutch operation and to deliver more torque & horsepower capacity. All parts are made from the highest quality materials to ensure trouble free operation. The Kevlar clutch plates are made for heavy duty operation and deliver a smooth power transfer to the rear wheel. The adjustable coil springs allow you to tailor your clutch lever pressure and operation as needed. These kits also boast very low maintenance and are a great choice for upgrading.

PCP Application

21819	1990-97
21820	1998-06



T/L Easy Clutch Kit for Twin Cam

This kit features a clutch spring and inner/outer ramps that significantly reduce the effort required to use the clutch lever. Fits 1999-05 Twin Cam models (stock on 2006-on) but is not compatible with screamin eagle performance parts.

29030



Auto Slip Clutch

Fits all BDL belt drive units.

21780

Clutch Lever



BT Hydraulic Clutch Handle Kit

Includes chrome handle assembly, chrome trans side cover, rod and hydraulic line.

- 59552** Kit
- 59553** Clutch handle assembly only
- 59884** Cover only 1999-on TC-88



Foot Clutch Conversion Kit

Allows the use of Police rocker clutch on 1987-99 FXST, FLST where the clutch cable goes directly into the trans side cover. Kit includes bracket and cable. May not be used with front engine bar.

- | PCP | Description |
|--------------|-------------------------|
| 59672 | Kit (bracket and cable) |
| 59331 | Cable only |
| 16216 | 1.25 Spacer block |
| 16245 | 1.75 Spacer block |

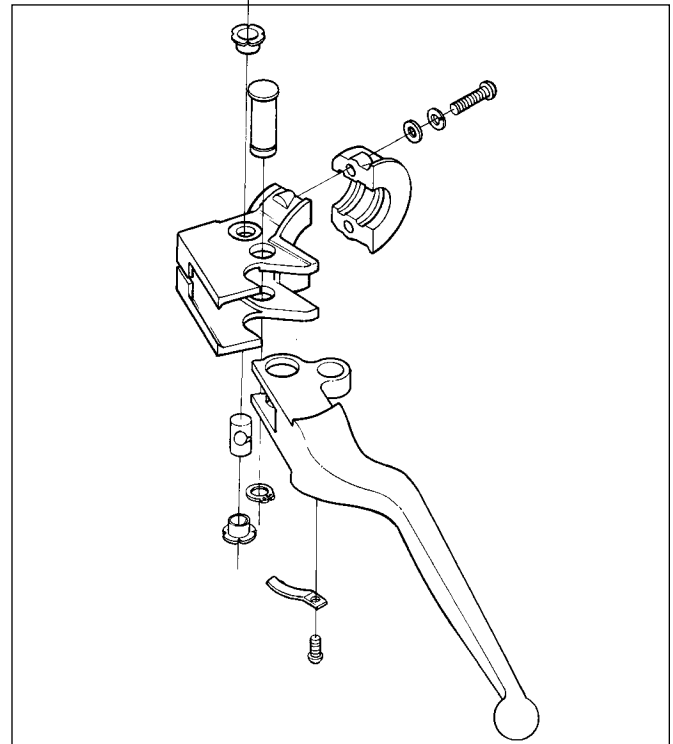

1982-95 Chrome Clutch Lever Components.

#	PCP	OEM	Description
1	24509	4015	Screw (5 pack)
2	12003	6099	Washer (10 pack)
3	11035	11143	Snap ring (10 pack)
4	50206	38608-82A 45044-82	Chrome bracket and clamp
	50205		As above with black finish
5	2441	45062-82	Clutch lever 1982-92
	50202	45047-93	Clutch lever 1993-95
6	13003	45021-86	Anti-rattle spring (5 pack)
7	10159	45032-82	Lever pin (each)
8	10164	45036-82	Cable pin 1982-87 (each)
	10165	45036-88	Nylon cable pin 1988-on (5 pack)
9	13411	45423-92	Bushing 1992-on (10 pk)
10	46007	45044-82	Black clamp
	46005	45044-82	Chrome clamp

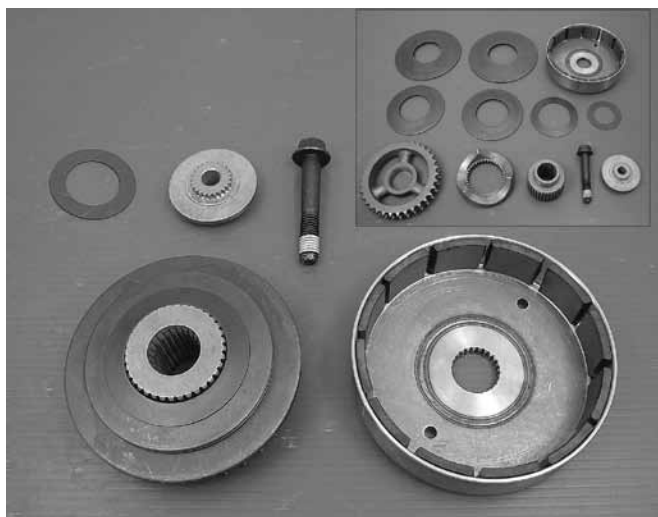

BT Compensator Kit Twin Cam 2007-on

Fits Twin Cam 2007-on and includes a heavy duty alternator rotor. The compensator unit includes heavier springs and an increase travel feature. This will aid in energy absorption of big cube motors with high torque abilities performing street drag launches.

65431



FXST Rocker Clutch Kit 1987-99

Includes rocker assembly, cable bracket and spacer block.

- | PCP | Finish |
|--------------|--------|
| 59514 | Chrome |
| 21807 | Black |

XL Clutch 1985-90

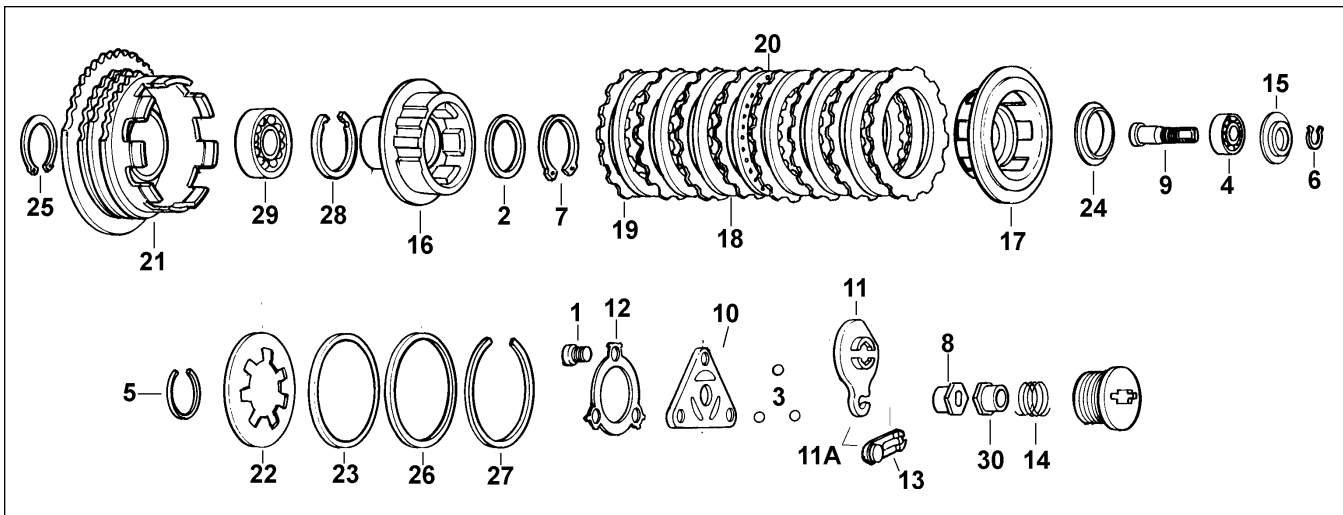

XL Clutch Hardware 1985-90

#	PCP	OEM	Description	#	PCP	OEM	Description
1	24055	3583	Bolt (each) 1985-93	15	36141	36730-84	Bearing guide
2	11519	5707	Spacer (each)	16	65412	36785-84	Clutch hub
3	15574	8873	Check valve ball (10 pack)	17	65413	36786-84	Pressure plate
4	15704	8885	Bearing	18	38908	36787-84	Steel drive plate (each)
5	11082	37909-90	Guide retaining ring (ea) 1990-*	19	38972	36788-84	Friction plate (set of 7)
6	11023	11046	Adjusting screw snap ring (10 pk)	20	36142	36789-84	Centre spring plate
7	11041	11164	Clutch hub retaining ring (10 pk)	21	37241	36791-84	Clutch hub shell with magnets
8	12528	11730A	Adjusting screw nut (each)	22	38920	36792-84	Pressure plate spring
9	24532	11735B	Adjusting screw 1985-93	23	36145	36793-84	Centre spring set
10	36139	25408-84	Inner ramp 1985-93	24	36143	36794-84	Inner spring seat
11	37103	25409-86A	Outer ramp L1986-93	25	11073	36795-84	Clutch hub retaining ring (5 pk)
11A	36140	25409-84A	Ramp & coupler kit 1985-93	26	36144	36796-84	Outer spring seat
12	13710	25448-84	Ramp lock plate 1986-93 (10 pk)	27	11074	36797-84	Press. plate retaining ring (each)
13	37104	34920-86A	Cable coupling 1986-on	28	11075	36798-84	Clutch hub retaining ring (5 pk)
14	13184	36715-84	Adjusting spring 1984-93 (10 pk)	29	15728	36799-84	Clutch bearing
				30	13742	36802-84B	Lock plate filler plug (5 pk)



Alternator Rotor Clutch Shell Assembly

Features vibration proof magnet construction, as magnets are held in place by stainless steel non magnetic insert for durability. Replaces 36791-84. Fits 1984-90. Bearing and ring gear included.
37241



Clutch Ramp Assembly Kits

Includes all necessary hardware for installation.

PCP	Year
16609	1994-on
16608	1986-93

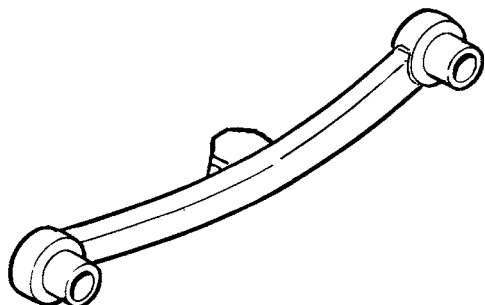

XL Shift Cam Follower 1985-90

Made from durable steel to replace OEM 34063-84.
36123

XL Clutch 1991-on

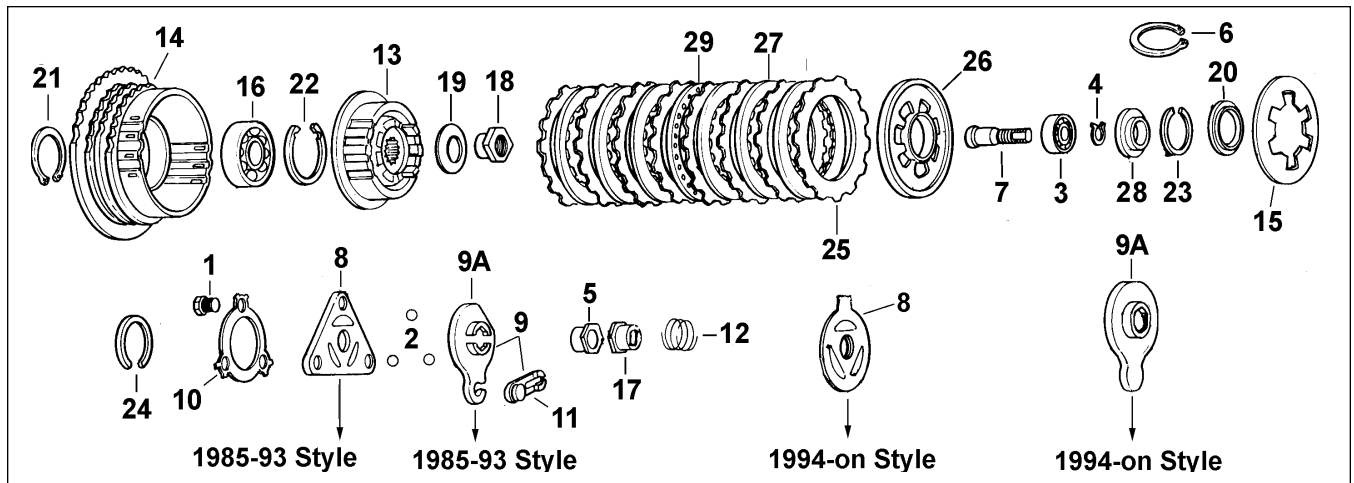

XL Clutch Hardware 1991-on (not XR1200)

#	PCP	OEM	Description	#	PCP	OEM	Description
1	24055	3583	Bolt 1985-93	14	65415	36790-91	Clutch shell 1991-03
2	15574	8873	Check ball 1991-* (10 pack)	15	65427	36790-04	Clutch shell 2004-* (not XR1200)
3	15704	8885	Bearing 1991-*	16	15738	36799-91	Ball bearing
4	11023	11046	Adj. screw ret. ring 91-* (10 pk)	17	13742	36802-84B	Well type lock plate (5 pk)
5	12528	11730A	Well nut 1991-*	18	12603	37495-91	Main shaft nut
6	11052	11250	Retaining ring 1994-on (10 pk)	19	20501	37870-91	Spring washer
7	24532	11735B	Adjusting screw 1991-93	20	62107	37872-90	Inner spring seat
	24533	11752	Adjusting screw 1994-03	21	11077	37904-90	Retaining ring
	24564	11765Y	As above 2004	22	11079	37905-90	Retaining ring (each)
8	36139	25408-84	Inner ramp 1991-93	23	11081	37908-90	Retaining ring
	37102	25453-87A	Inner ramp 1994-on	24	11082	37909-90	Retaining ring 1990-on
9	36140	25409-84A	Ramp & coupler kit 1991-93	25	38977	37911-90	Barnett clutch plates (set of 8)
9A	37103	25409-86A	Outer ramp 1991-93	26	62109	37912-91	T/L Pressure plate
	36148	25409-94B	Outer ramp clutch 1994-on		71035	37912-91A	Preston, as above
10	13710	25448-84	Lock plate 1986-93 (10 pk)	27	38961	37913-90	Steel plate (sold each)
11	37104	34920-86A	Cable coupling	28	36149	36731-91	Release plate with bearing
12	13184	36715-84	Clutch adj. spring 91-93 (10 pk)	29	62110	37977-90	Spring plate with magnets
	13210	36715-94	Clutch adjusting spring 94-on				
13	65416	36785-91	Clutch hub 1991-on				

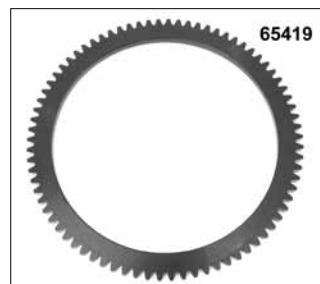
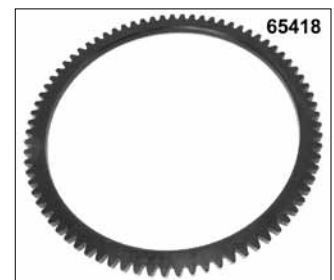
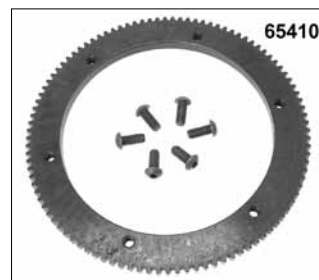
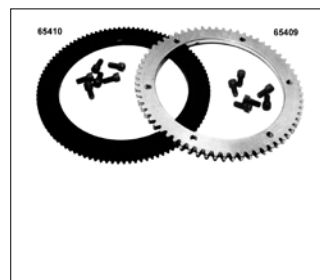

Starter Ring Gears

For replacement on stock clutch hubs only.

PCP	Description
65409	BT 1990-93 (66T) (bolt-on)
65410	BT 1994-97 (102T) (bolt-on)
76076	BT 1998-06 (102T) (bolt-on)
65418	XL L 1984-90
65419	XL 1991-on

Barnett Clutch Cables

For Big Twin FX & Dyna Models

Black Vinyl		Stainless Steel		Fits
STD	Oversize	STD	+8"	
47125				FXCWC 2008
7439	7440 +8"	47872	47873	FXDB (Dyna) 1991 (38607-87A)
47119	-	47876	47877	FXD/B/C/L/S 1992-99 (38602-92)
				FXDS-Convertible 1996-05
				FXDWG 1996-05
				FXDWG-I 2004-05
47110				FXD 2000-05, FXD-I 2005, FXDC/I 2005
				FXDL 2001-05, FXDL-I 2004-05
47131				FXDX 2000-05, FXDXT 2002-04
				FXDB-I 2006-08, FXDWG-I 2006-07
47130				FXDWG Anniversary 2008
				FXD-I 2006-08, FXDB-135 2006-07
47129				FXDC 2006-07
				FXDC 2008
47132				FXDL-I 2006-08
7453	47118 +6"	47870	47871	FXDF 2008
7453	47118 +6"	47870	47871	FXEF 1979-85 (38618-68C)
7441	-			FXSB 1983-85 (38618-68C)
				FXLR 1987-95 (36753-87A)



Barnett Clutch Cables are made from the finest materials available, with casings constructed from hard-drawn spring wire steel. All Barnett clutch cables are made with nylon-lined black PVC coating with a 1/8" diameter inner cable. Some cables are available in heavy-duty strand, larger diameter nylon-lined casings. Some cables are offered in +8" extended size. All stainless steel cables are clear coated.

For Big Twin FXR Models

Black Vinyl		Fits
STD	Oversize	
7435	-	FXR 1983-86 (38599-83A)
7437	7438 +6"	FXR 1987-94 (38606-87A)
7435	-	FXRD 1986 (38599-83A)
7435	-	FXRDG late 1984 (38599-83A)
7435	-	FXRS 1983-86 (38599-83A)
7437	7438 +6"	FXRS 1987-1995 (38606-87A)
7437	7438 +6"	FXRS Convertible L89-95 (38606-87A)
7435	-	FXRS Sport Edition L85-86 (38599-3A)
7442	-	FXRS Sport Edition 87-94 (36755-87A)
7435	-	FXRT 83-86 (38599-83A)
7437	7438 +6"	FXRT 87-92 (38606-87A)
7439		FXR-2, FXR-3 1999-00
47121		FXR-4 2000



Clutch Cable Adjuster Cover

Die cast, chrome, two piece cover installs over clutch adjuster using two snap rings so the clutch cable does not have to be removed. Fits BT L1987-99, XL 1988-99.

44032

For Sportster XLH Models

Black Vinyl		FITS
STD	Oversize	
7449	7450 +8"	883 86-95, 883C 1999-08 (38619-86A)
7449	7450 +8"	883 Deluxe 1987-95, 883 STD 1996-08 (38619-86A)
7451	7452 +8"	883 Hugger L1987-95 (38621-86A)
47124		883 Hugger 1996-01 (38620-96)
7449	7450 +8"	883 Hugger 2002-03, 883R 2002-03 & 2006-08 (38619-86A)
7449	7450 +8"	883L 2002-06 (38619-86A)
7451	7452 +8"	1100 1986-87 (38621-86A)
7451	7452 +8"	1200 1988-95 (38621-86A)
47124		1200 STD 1996-01
		1200C 1996-99
		1200S 2002-03 (38620-96)
7449	7450 +8"	1200S to 2001
		1200C 2000-08
		1200N 2008
		1200 STD 2002-03
		1200R 2004-08 (38619-86A)
		1200S to 2001
7449	7450 +8"	XLH 50 2007



Chrome Billet Clutch Cable Mount

Fits Softail models.

73707

Barnett Clutch Cables



Heat Shrink Tubing for Braided Cables

Use clear heat shrink tubing on all braided stainless steel cables to prevent scratching of chromed or painted surfaces. Kit contains 4-16" long heat shrink tubes to cover 2 throttle cables, 1 clutch and 1 speedo cable. Bulk tubing comes in a 10 foot roll.

PCP	Application
28713	Cable sleeve kit
28714	3/8" x 10' roll
28715	1/2" x 10' roll
28716	3/4" x 10' roll



Clutch Cable Adjuster Cover

Chrome plated polished brass cover fits 1987-on BT and XL. Cover locks into place over adjuster at the clutch cable adjustment cover: when secured by a stainless screw kit. Cover will retro fit to Barnett or stock cables.
44018



Clutch Cable Boot

Rubber boot fits over the in-line adjuster on BT and XL 1988-99.
23061 38630-88

For Big Twin FL Touring Models

Black Vinyl		Stainless Steel		FITS
STD	Oversize	STD	+8"	
7453	7433 +8"	47870	47871	Heavy duty 4-spd BT '68-86 (38618-68C)
7439	7440 +6"	47872	47873	FLHS late 1987-88 (38607-87A)
47104	-	47878	47879	FLHS 1989-95 (38601-89)
				FLHR 94-06, FLHRP 1996-01
				FLHR-I 1996-06, FLHRC-I 1998-06
				FLHRS/I 2004-06
				FLTC 1989-95
7435	-	-	-	FLT/HT, FLTC 1983-86 (38599-83A)
7439	7440 +6"	47872	47873	FLHT 1987-89, FLTC 87-88(38607-87A)
47104	-	47878	47879	FLHT 1990-05 (38601-89)
				FLHT-I 2005-06
7435	-	-	-	FLHTC 1983-1986 (38599-83A)
7439	7440 +6"	47872	47873	FLHTC 1987-88 (38607-87A)
47104	-	47878	47879	FLHTC 1989-06 (38601-89)
47104	-	47878	47879	FLHTC-I 1996-06
				FLHTC Ultra 1989-95 (38601-89)
				FLHTC-I 1996-06
				FLHTCU 1990-2000, FLHTCU-I 1996-06
				FLHX-I 2006
				FLTR 1998-02, FLTR-I 1998-06

For Heritage Models

7436	-	-	-	FLST late 1986 (38611-86)
7439	7440 +6"	47872	47873	FLST 1987-1990 (38607-87A)
7439	7440 +6"	47872	47873	FLSTC late 1987-1999 (38607-87A)
47110	-	-	-	FLSTC 2000 (38604-90)
				FLSTC/Heritage/F/I 2000-06
47125	-	-	-	FLSTC 2007-08
7439	7440 +6"	47872	47873	FLSTF 1990-1999 (38607-87A)
47110	-	-	-	FLSTF//F/ 2000-06 (38604-90)
47126	-	-	-	FLSTF 2008
47125	-	-	-	FLST/F 2007
7439	7440 +6"	47872	47873	FLSTN 1990-99 (38607-87A)
				FLSTS 1996-99
47110	-	-	-	FLSTN-I 2005-06
47126	-	-	-	FLSTN 2007-08
47110	-	-	-	FLSTS-I 2000-06 (38604-90)
47125	-	-	-	FLSTSC 2007

For Softail and FXWG

Black Vinyl		Stainless Steel		FITS
STD	Oversize	STD	+8"	
7453	47118 +6"	47870	47871	FXST 1984-85 (38618-68C)
47106	47107 +8"	47108	-	FXST 1986 (38605-86)
7439	7440 +6"	47872	47873	FXST 1987-99(38607-87A)
47110	-	-	-	FXST 2000 (38604-90)
				FXST-I STD 2001-06
47106	47107 +8"	-	-	FXSTC 1986 (38605-86)
7439	7440 +6"	47872	47873	FXSTC 1987-99 (38607-87A)
47125	-	-	-	FXSTC 2007-08
47114	-	-	-	FXSTD/-/F-I 2000-06 (38639-00)
				FXSTD-SE 2003-05
47126	-	-	-	FXST STD 2007-08
				FXSTD 2007
7439	7440 +6"	47872	47873	FXSTS late 1988-99 (38607-87A)
47110	-	-	-	FXSTS 2000-06 (38604-90)
				FXSTS-I Springer F/I 2001-06
47121	-	-	-	FXSTSB 1995-97 (38617-95)
47112	-	-	-	FXSTB, FXSTB-I 2000-06 (38665-00)
47133	-	-	-	FXSTB 2007-08
7453	47118 +6"	47870	47871	FXWG 1980-86 (38618-68C)

Clutch Cables

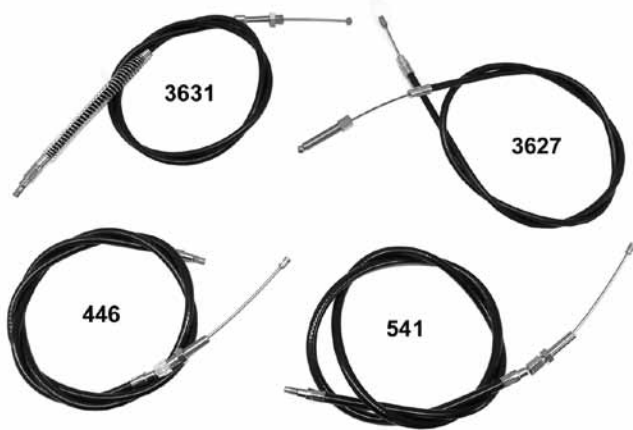

Stainless Steel Clutch Cables

PCP	Model/Year
47620	Stock XL 883 1986-on
47622*	Stock FXST-FLST 1987-99 (clear coat)
47623*	+8 FXST-FLST 1987-99
47610	Stock FXR 1983-86

Note: 47622 & 47623 have eyelet-type end

FLH MODELS

PCP Fits

- 541 FL 1968-86 STD length barrel end (38618-68)
- 446 1968-86 +6" Longer barrel end (38618-68)
- 3627 1979-on STD length ball end (38618-68A)

FLT MODELS

- 3631 FLT, 1984-86 FLHTC, FLTC, FLHT, Classic 1983-86 STD length (38599-83)

FX MODELS

- 3627 FXST 1984 STD Length (38618-68A)
- 3631 FXR, FXRS, FXRT 1983-86 STD length (38599-83A)



+12" Clutch Cables

With black vinyl casings for use with those high handlebars.

- 47301 FXST 1987-99



M&M Clutch Cables

Constructed from Supra stainless steel braid which is tightly woven for a bright, quality consistent finish. Features UV resistant, heat bonded, non yellowing clear coat for lasting performance. All applications include adjuster, inner lengths and correct fittings for exact installation and fitment. Cables are stock length except where noted.

PCP	Application	Length
21840	2007-on BT	72.81"(extended)
21841	2007-on FLT (38667-07)	62.51"
21842	2006-on FXDWG (38789-06A)	68.81"
21843	2007-on FXST (38666-07)	64.75"
21844	2007-on FXSTD (38664-07)	62.66"
21845	2006-on FXD (38787-06A)	64.57"
21846	2006-on FXDL (38788-06A)	65.66"



Cable Brackets and Adapters

PCP Fits

- 16200 (A) Chrome clutch cable support bracket for all 5 speed models 1980-86. Keeps cable away from cylinders (each)
- 3271 (B) Chrome FLH clutch cable router 1968-84. (5 pk)
- 1297 (D) Chrome cable repair clamp for levers (each)

BT 4 Speed Gear Box

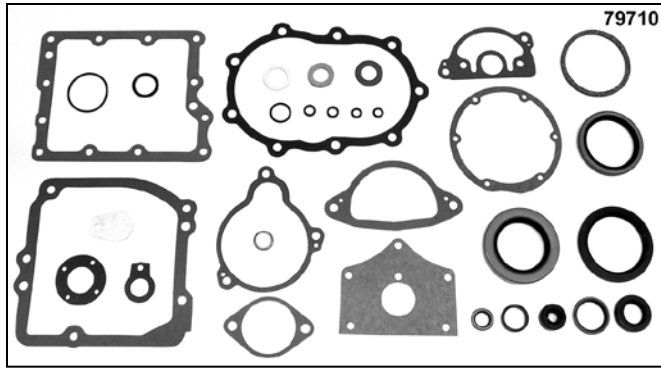

Transmission Gasket Kits for Big Twin

Transmission kits contain all the gaskets and seals needed to rebuild Big Twin transmissions.

James Fits

79710	1980-86 Big Twin 4-spd (33031-80)
79706	1980-99 Big Twin 5-spd (33031-85)
79707	1991-98 Dyna (33031-91)
79708	1993-on FLT, FLHS (33031-93)

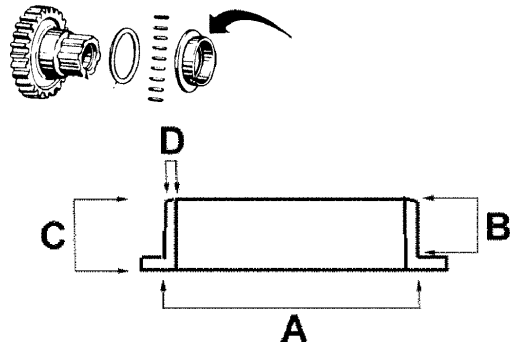

For Big Twin 4 Speeds 1982-86

PCP	Description	A	B	C	D
11501	All chain drive 1982-85 (35079-82A, 35079-84)	2.062	.320	.402	.272
11500	All belt drive 1982-86 (35070-82A)	2.062	.370	.455	.272



Magnetic Drain Plugs

PCP	Size	Use
10610	3/8 x 24	BT Case plug (700 not magnetic)
10611	1/2 x 13	74 & XL Trans (707)
10615	1/4 x 18	NPT chain cover (718)
10612	5/8 x 18	Oil tank & time hole (720)
10616	5/8 x 18	FXR drain (722A)
10613	1/8 x 27	NPT 1987-89 BT primary trans FXST-FXR (734, 739A)
10614	1/8 x 27	As above with Hex
10619	1/8 x 27	NPT 1990-on BT trans (739A)
10618	1/2 x 20	74 & 80 Inner primary (60348-65A)

Prevents metal particles from circulating through engine and transmission cases, oil tanks, etc.

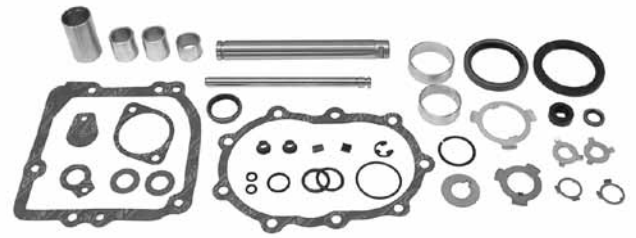

Trans Rebuild Kits-Jims

These kits have proven Jims Machining parts to start with and then complimented with James Gaskets.

31273 Big Twin 4 speed 1980-86



4 Speed Transmission Assembly

Fully assembled and includes all internal parts, chrome kicker cover and components, rotary top, mount studs, and clutch hub nut. Unit will accept belt or chain final rear drive and features later mainshaft to accept 84-90 clutch hub and components. Fits FXB models with the substitution of a rotary shift linkage.

58022 FXST 1984-85, FXWG 1985-86



STD FXST 4 Speed Transmission Case 1985-86

Supplied with a custom bearing race that accepts the 1985-86 bearing on 4 speed FXST models.

36789



Eastern Transmission Mainshafts- USA

36182 L1984-86 4 speed belt drive (35039-85)

Big Twin Trans Mount

27122

27263



Chrome Steel Transmission Mount Plates

PCP	Application
27263	Rigid mount 5 speed trans in 4 speed Paughco frame, chrome
27121	Black FXST, FLST 1986-99 (47698-86B)
27122	As above, chrome



BT Acorn Trans Mount Kit

Includes bolts and washers necessary for installation.

PCP	Year	Finish
9420	1977-86	Chrome
9421	1977-86	Zinc
9867	1986-on	Zinc, FXST 5 speed
9866	1986-on	Chrome, FXST 5 speed



Chrome FXST Transmission Plate Kit

Kit includes transmission mount plate and installation hardware.

27127



Trans Mounting Plate to Frame Kit

1800 Fits Big Twin 4 speeds 1936-86

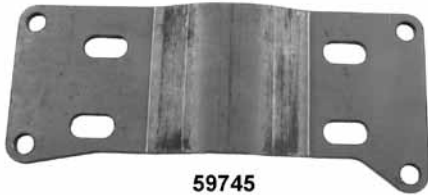

59745

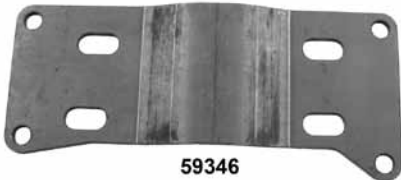

59346

Offset Transmission Plates

Fits 5 or 6 speed FXST transmissions.

PCP	Offset
59745	1/4"
59346	1/2"

Transmission Case Bottom Stud

Colony reproduction studs are 7/16-14 x 3/8-24. Fits Softail 1984-on.

9863 11733 (5 pack)



BT 5 & 6 Speed Bearing Support Plate 1984-00

Fits 1984-2000 BT models with kickstart. Billet aluminum support plate includes bearing.

21778

Andrews BT 4 Speed



4 Speed Trans Top 1979-86

All parts completely assembled with a natural finish except the chrome plated arm with grease fittings. USA made.

PCP Application

36904 FLH
36906 FXE

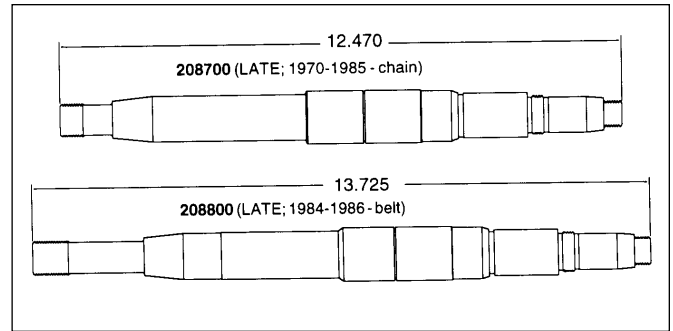

Andrews Products makes four different versions of 4 speed Big Twin mainshafts

Regarding mainshaft H-D # 35039-84, fits belt drives. This is the same part as H-D #35039-85 except that 35039-85 uses a different drive key. **It is very important that the correct drive key be used.** It is H-D # 37523-85. Andrews part number for this shaft is **208800**.



Trans Plugs



Oversize Drain Plug and Tap Kit

Contains 1 chrome plated dome head plug with an oversize thread and one tap for rethreading the stripped out drain hole. Fits O.H.V. Big Twin Harley Engines 1965-on.

1760 Kit
1761 Oversize drain plug only

Transmission Mainshafts

Replacement mainshafts for all versions of BT boxes. Made from aircraft alloy steel with heat treatment and finish grinding to ensure maximum durability.

208700 35039-70A 1970-E85 chain drive
208800 35039-85 1985-86 belt drive



Timing Plug - Oil Tank Plug

Chrome plated plug fits Harley Davidson timing holes. 5258 1981-on Big Twins (1/2 x 20)

Transmission Countershafts

Replacement countershafts fit transmissions thru 1985. They are not interchangeable, so be certain before you order.

207800 35614-80 1980-85



Oversize Timing Plug and Tap Kit

Contains 1 chrome plated acorn head plug with an oversize thread and one tap for rethreading the stripped out timing hole. Fits all Harley Davidson timing holes.

1758 Kit
1759 Oversize timing plug only

BT Rotary Shifter 1979-86

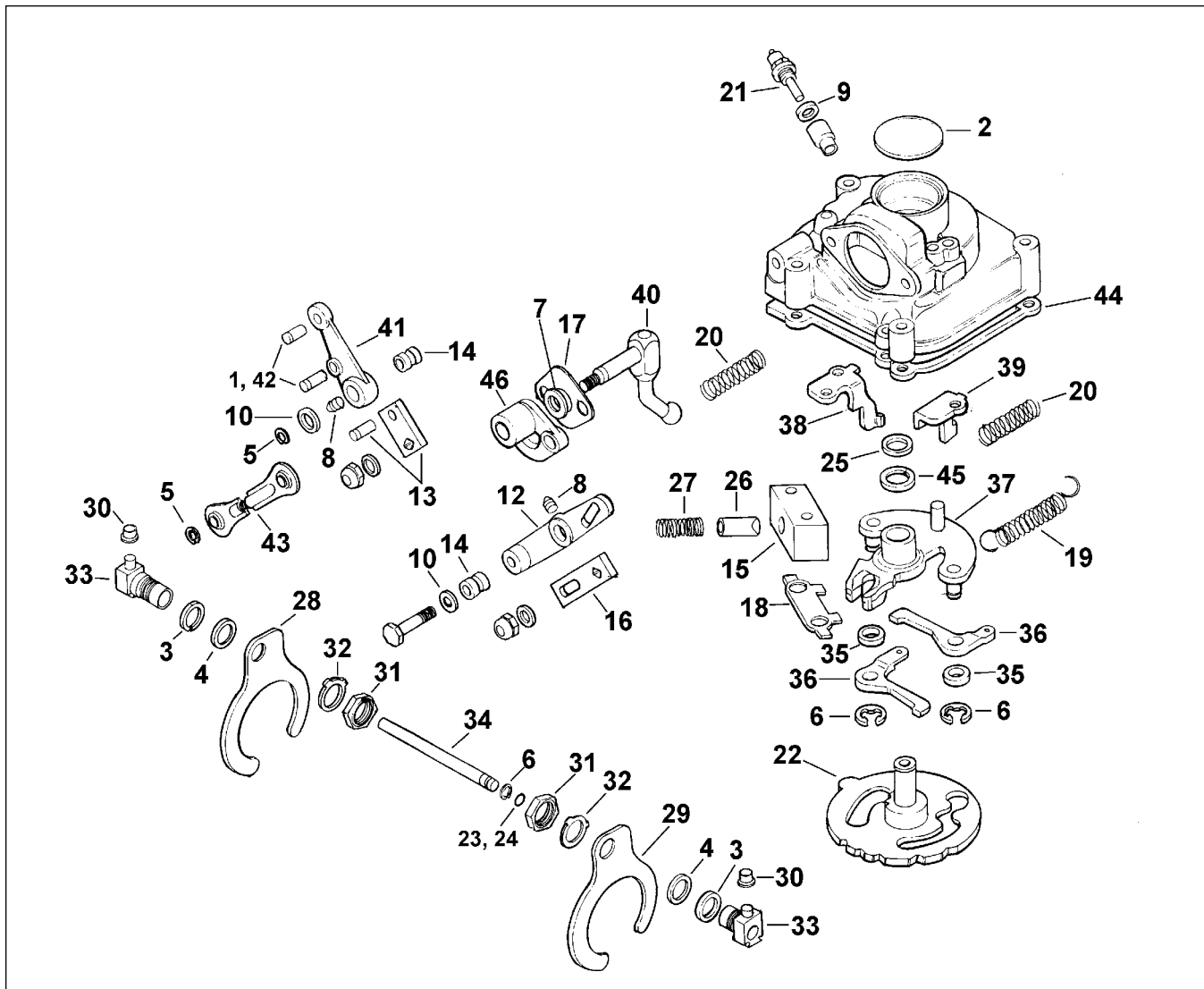

#	PCP	OEM	Description	#	PCP	OEM	Description
1	10100	215	Lever pin FWXG 1980-on (10 pk)	25	11062	34040-52	Retaining ring (10 pk)
2	10602	650	Plug (each)	26	36102	34062-52	Cam follower (ea)
3	13555	6750	Shim (.007) (10 pk)	27	13178	34068-52A	Cam follow spring (10 pk)
4	13556	6752	Shim (.015) (10 pk)	28	228	34158-36	Main shift fork (ea)
5	11011	11016	Snap ring (10 Pk)	29	229	34159-36	Countershaft shift fork (ea)
6	11018	11036	Pawl retainer (10 pk)	30	1544	34168-52	Finger roller (2) (pr)
7	14010	12010	Cover oil seal (5 pk)	31	12549	34179-33	Bushing nut (ea)
8	10515	25715-47	Grease fitting (10 pk)	32	13723	34180-33	Lockwasher (10 pk)
9	79116	25811-11	Switch washer (20 pk)	33	36115	38184-79	Shift finger (ea)
10	11533	32535-48	Lever washer (5 pk)	34	36116	34186-76	Fork shaft (ea)
12	4787	33177-79	Lever complete FL-FXWG (ea)	35	36117	34461-72	Shift pawl spacer (pr)
13	36111	33185-79	Shift rod assembly FX-FXE (ea)	36	36118	34476-72	Shifter pawl (1979-86) (ea)
14	18700	33187-79	Spacer STD (5 pk)	37	36119	34494-74C	Pawl carrier (ea)
	18701	-	Spacer .020 O.S. (5 pk)	38	36120	34517-80	Rear pawl stop (ea)
15	36112	33188-79	Plunger body (ea)	39	36121	34518-80	Front pawl stop (ea)
16	36113	33190-79	Lever arm FL-FXWG (ea)	40	36122	34652-80	Shift lever shaft (ea)
17	25111	33196-79	Cover gasket, shifter (10 pk)	41	16528	34655-79	Lever complete FX-FXE (ea)
18	13715	33197-79	Bolt lock (10 pk)	42	10137	34658-79	Lever pin (ea)
19	13169	33199-79	Pawl spring (10 pk)	43	16562	23659-79	Rod linkage FX (ea)
20	13170	33201-79	Carrier spring (10 pk)	44	79324	34824-79	Cover gasket L1979-86 (10 pk)
21	28101	33901-79	Neutral switch (ea)	45	11532	35336-74	Thrust washer (5 pk)
22	36114	34020-79B	Cam assembly (ea)	46	36137	33174-79	Chrome shift cover (each)
23	14039	34036-36	Oil seal (10 pk)				

Shifter



Shift (left side) FXST

- 90204** Kit as pictured
- 12001** Nylon washer (6057)
- 14562** O-ring (11191) (10 pk)
- 37205** Shift lever (33660-90B)
- 61055** Lever bracket (33683-00)
- 18635** Bracket bushing (33708-94)
- 36133** Shifter rod kit (33719-79A)
- 37518** Shift lever arm (34564-90A)
- 3247** Shifter rubber w/chrome (34611-65)
- 1147** As above, all rubber



Shift (left side) FLST

- 90205** Kit as pictured
- 12001** Nylon washer (6057)
- 14562** O-ring (11191) (10 pk)
- 61054** Lever bracket (33630-00)
- 36133** Shift rod kit (33719-79A)
- 37207** Shift lever (33668-90B)
- 18635** Bracket bushing (33708-94)
- 37516** Shift lever arm (33895-82)
- 3247** Shifter rubber w/chrome (34611-65)
- 1147** As above, all rubber



Refer to OEM Parts book for breakdown



FXST Jockey Pedal/Handle Kit

Includes chrome pedal, plate, cable, and chrome handle. Skull knob shown is not included.

- | PCP | Application |
|--------------|---------------------|
| 59328 | 1986-99 Kit |
| 59329 | 2000-on Kit |
| 59330 | 5 Speed handle only |
| 59331 | 1986-on Cable |



BT Jockey-Rocker Clutch Kit 1987-on

Includes a slap-stick and complete chrome rocker clutch assembly. Jockey handle mounts directly to trans selector arm. Fits 1987-on 5 speed Softail models.

90329

Shifter



Shift Control Cover Kit FL Softail 2000-06
63052 (33825-00)

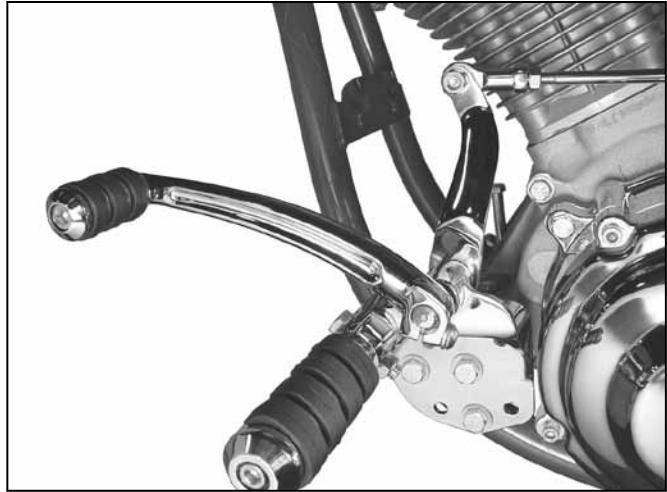

Chrome Billet Shift Lever 1990-on
59134 Softail 1990-on and Dyna 1991-on



Shifter Pegs

PCP	Style	Type
39019	O-Ring	Rotating
39017	Railer	Chrome with rubber
39024	Cats Paw	Chrome with rubber, 3/8" stud
39025	Cats Paw	Chrome with rubber, 5/8" stud
39018	Cats Paw	Chrome with rubber 1" longer
1402	O-Ring	Chrome with o-ring
1147	Stock	Black with 1/2" stud
5432	Stock	Black with 3/4" stud
5433	Stock	White with 3/4" stud



Chrome Billet Shift Lever

Features slotted design and fits 1990-on Softail and 1991-on Dyna.

61085 Shift lever only (34539-00)

39025 Cats Paw shift peg sold separately



Chrome Diamond Accent Shift Peg

Peg features diamond shape rubber insert and short stud (1/2"), chrome casting and fits 1941-on models.

39142



Batique Shift Peg

73701



Self-Aligning Rod Ends

Heim joint type swivel allows alignment at up to 28° off centre, self lubricating brass ball socket available for shifter or brake rod ends, 5/16 x 24 thread, for rod end, with integral stud (5/16 x 24) or with 5/16 hole for attaching as direct bolt on.

4639 W/stud, chrome 1-7/8"

37202 W/hole, zinc 1-3/4"

37208 As above, chrome 1-7/8"



Forked Rod End Clevis

Clevis has 5/16 x 24 threads for use on shifter or brake rods.

PCP Pin Size

37217 1/4"

37218 5/16"

Chrome Heim Joints

Heim joints have a variety of uses and are especially useful for custom shift and brake linkage creation. The 5/16" joints are available with left or right hand threads.

PCP	Size	OAL
71009	1/4" x 1/4-28 female	1-3/4"
71014	5/16" x 5/16-24 female	1-7/8"
71013	5/16" x 5/16-24 female	2"
71010	5/16" x 5/16-24 male	2-1/4"
71011	5/16" x 5/16-24 female	2-7/8"
71012	5/16" x 5/16-24 male (LHT) (zinc)	2-1/4"
71015	3/8" x 3/8-24 female	2-1/8"



Chrome 5/16" Shift Rod Extension

With male and female ends.

PCP Length

73640 2"

73641 3"



Chrome Straight Shift Rods

Rods measure 5/16" in diameter with 5/16 x 24 thread at each end.

PCP	Length	Finish
37193	3-5/8"	Chrome
37194	7-3/4"	Chrome
37195	10-5/8"	Chrome
37211	11"	Chrome FXST 1985-99
37198	11-3/4"	Chrome
37191	12-1/2"	Chrome
37192	13-1/2"	Chrome
37199	14-1/2"	Chrome
37201	20-1/4"	Chrome



Shift Rod Jam Nuts

Features tapered design to cover excess rod thread. Pairs.

12653 5/16 x 24

Shifter Brackets

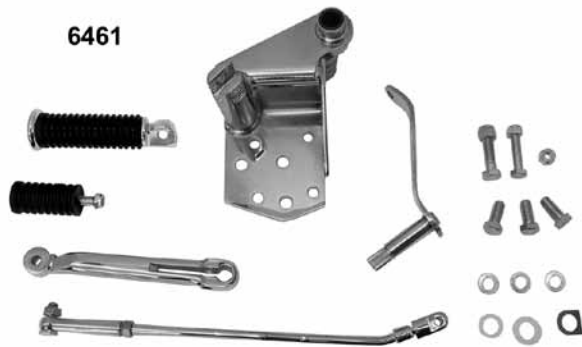

FXST Replica Forward Shifter Kit

Complete kit with all hardware necessary for installation on 4-speed models 1952-84, 1981-on 5-speed Big Twin models. Use in conjunction with our FXST Replica Controls, as all kits place pegs in a forward position parallel to the peg on brake side. Foot rests on peg while shifting for added comfort. This is an exact stock replacement in chrome for the 1980-85 FXWG, 1984-on FXST. Kit includes chrome heavy duty shifter bracket, inner lever shifter lever, rod, rubber shift peg and foot peg, display packaged and labelled with detailed instructions and assembly diagram for each model listed below.

- 6461** FXWG-FXST Rotary Top 4-Speed
- 6462** 1981-on 5-Spd. FXR-FXS-FXRS
1985-on FXST-FXSTC 5-Speed



Chrome Shifter Control Kit

For 1980-85 FXWG 4 Speeds and FL, FXST.
6319



Chrome Shifter Shafts

A wide selection of all-chrome shifter shafts to replace the OEM part on many Big Twin models 1970-91.

PCP Fits

- 3094** 5-speed FXR models with diaphragm clutch L84-87 (34621-84)
- 11016** Retaining ring for the shift arm on 1965-86 4-speeds. (11031) (10 pack)



1980-on FXWG-FXST Shifter Bracket

This heavy duty bracket features a built in footpeg mount and chrome finish. Peg clevis is aligned to match with forward brake mounts. Fits FXWG models 1980-86, FXST 1984-89 and many custom applications. Replaces 33683-80.

1454

Chrome Shift Mount Bracket

One piece design fits FXST 1990-99.

27303 33683-90A



Chrome Inner Shift Levers Softail 2000-on

PCP Type

- 59637** Solid FXST 2000-06 (33660-90B)
- 59638** Slotted as above
- 37522** Solid FXDWG 2003-05 (33789-03)
- 37523** Solid FXST 2007-* (33660-07)
- 37524** Solid FLST 2007-* (33668-07)



Chrome Shifter Cover

Fits FLSTC/FL 1989-99.

45502 33642-89

Shifter Levers



XL Chrome Shift Lever

Fits Evolution Sportster models 1986-90. OEM 34606-86
Chrome.
2065



XL Chrome Shift Lever

Fits all 5-speed Evolution® Sportster®.
37510 1991-03 (34606-90)



Billet Chrome XL Shift Lever and Pedal

Fits 1991-03 Sportster models except 1999-on XL Custom.
Will not work with XL forward control kit #33891-98 and
33892-98.
59496



21699



21721

XL Chrome Shift Lever 2004-on

Fits 2004-on XL 5 speeds.

PCP Style

21699 Smooth (34660-04)

21721 Open slot



37511

1451



1451

37511

FXWG Chromed Shifter Lever

Fits models 1974-84 and FXWG models 1980-86 with 32T
splines (OEM 33664-81). Also fits 1984-85 FXST and 1981-
86 FLHS.

1451 Splined

37511 No spline



FXR Chrome Shifter Lever

Fits all FXR models 1982-94 and FXRT 1982-99 (OEM
34599-81)
3254

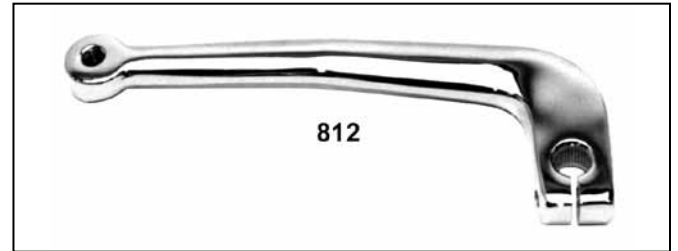

812



37518

FX Chrome Shifter Lever

Fits all FX models 1974-85 with shifter through primary case
and all Softail models 1986-on (except Heritage 1986-91)
Also fits 1991 Dyna Glide.

812 FX 1974-85 (34564-74A)

37518 TC 2000-on, FXST 1990-on, Dyna 1991-on
(34564-90A)

Shifter



Heel-Toe Shifter Lever

Chrome plated shifter. Fits all FL models 1965-84 with foot boards or forward controls.

PCP	Fits
4442	Non splined lever (34690-65)
3787	Splined lever (34690-74A)



Grease Eliminating Spacer

Stepped spacer with o-ring are designed to replace OEM 5702 on FLT 1980-on shift shafts.

11824



37521



Billet Heal Toe Shifter Set 1986-on

59640 FLST, FLT, FLHT 1986-on



Toe



Heel



Extended Chrome Shift Lever

Levers are 8-1/2" long for extended reach.

37519 1987-on FXST and 1986-05 FLT

Chrome Heel Toe Shifter

PCP Application

37515 FLT 1983-on, FLST 1986-on heel lever (33640-83)

37516 FLST, FLSTC and FLSTF 1986-92 Fits toe only on FLT 1983-on (each) (33895-82)

37521 1996-on FXD with floorboard kit #50601-01 or 50580-01 (33756-01)



Heel Shift Lever

Features swivel peg location to fold out of the way. Fits 1986-on FLST, 1988-on Touring.

37520



FLST-FLT Heel Toe Shift Lever

21708

36188



Greaseable Shifter Shaft (Thru Primary)

Will replace OE shaft to hold extra lube for added lubrication on FLT 1982-on.

36188

Shifter



Chrome Billet Skull Shift Rods

Order ends separately. Overall length includes threaded ends.

PCP **Length**

21752 12.25"

21753 11.00"



Chrome Maltese Shift Rod

PCP **Length**

59659 10-3/4"



Billet Twisted Shift Linkage FXST 1986-on

59661



FLT Shift Shaft Spacer Kit

Short spacers are for use with heel/toe shifters. Longer spacers are used to eliminate the heel shifter or for use on single shifter models.

PCP **Description**

11824 Short without ring 1980-on

11846 Short with anti-rattle washer

11847 Long with anti-rattle washer

Chrome Splined Shaft Cover FLT

1994-02

44093 37912-91A (each)



FX Shift Rod Kits

PCP	Application	Finish
36179	1990-05 FXDWG	Chrome
36180	1990-05 FXDWG	Zinc
21750	2006-on FXDWG	Chrome
21746	1991-05 FXD	Chrome
21747	1991-05 FXD	Zinc
21748	1991-05 FXD/L/X	Stainless Steel
21749	2006-on FXD	Chrome (for mid controls)



Billet Jockey Shifter Kit

Includes top mount and rod for 1986-99 FXST models. Order knob separately.

82107

Shifter

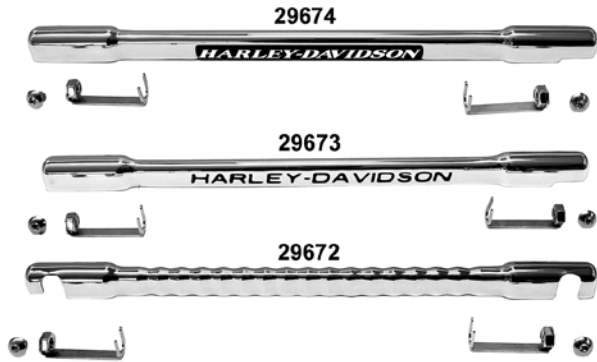

T/L Chr/Shift Linkage Covers 1999-on Touring

Chrome plated covers easily install over the stock shifter linkage. Covers include mounting hardware to fit 1999-on Touring models.

PCP Design

- 29672** Diamond (46301-01)
- 29673** Script (46303-01)
- 29674** Engraved medallion (46305-01)

T/L Chrome Shifter Linkage Cover-Softail

Chromed covers include mounting hardware and install easily over the stock shifter linkage. Fits 1999-on Softail models with stock shifter linkage. Does not fit FLSTS models or models using dual crossover exhaust systems.

PCP Design

- 62035** Diamond (46300-01)
- 62036** Script (46302-01)
- 62037** Engraved medallion (46304-01)

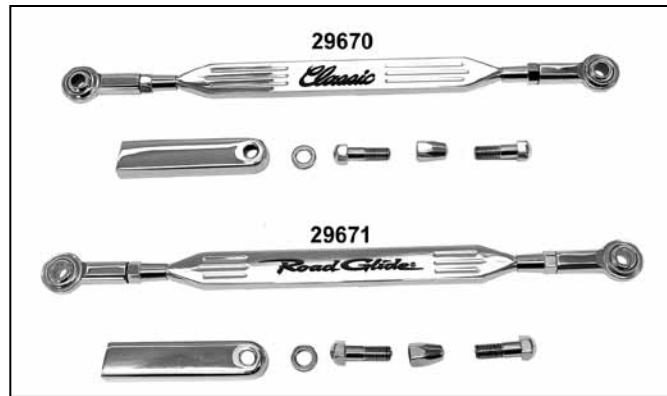

T/L Polished Dyna Shift Linkage 1991-on

Polished stainless steel linkage replaces original zinc piece.

- 62284** 1991-05 FXD, FXDX, FXDL, FXDS-Conv with mid controls (33872-00)
- 62285** 2006-on Dyna w/mid controls (33872-06)
- 62287** 2006-on FXD/WG w/forward controls (33815-06)

T/L Polished Stainless Steel Gear Shift Linkage

Polished stainless steel shift linkages are available to fit 1986-on Touring models. Easily installed linkages feature aircraft quality rod ends, steel transmission cover and acorn nuts for a finishing touch.

PCP Design

- 29670** "Classic" (33845-02)
- 29671** "Road Glide" (33846-02)



Chrome Billet Shift Rod Kit

Includes heim joint ends. Stock length rod is 10-5/8" long.

- | PCP | Style | Size |
|--------------|-------|--------------|
| 59269 | Round | Stock |
| 59263 | Slot | Stock |
| 59270 | Slot | +3" extended |

Transmission Plugs

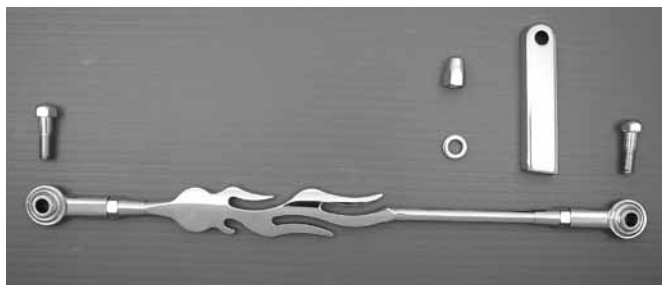

Chrome Flame Shift Rod Kits

Includes ends. Length is rod length with threads included.

PCP	Model	Length
59662	1993-on FXDWG	11 x 3/4"
59663	1994-on FLHR	11 x 3/4"
59664	1986-on FXST	10 x 1/2"
59666	FXST	+2"
59667	FXST	+3"



Transmission Plugs

- C. Transmission Fill Plug/Dipstick fits Evo 5 speed trans.
2865 Chrome 1985-86
9861 Chrome 1987-on
- D. Cap style custom fill plug fits Evo 5 speed trans 1985-86
5393 Chrome Plated
5394 Gold
9401 Brushed aluminum
- J. Chrome allen transmission filler plug for BT 1987-on
9885 (37075-87)



XL Chrome Shift Lever Assemblies

Includes Iso shift peg.

PCP	Application
21718	1986-90
21719	1991-03
21720	2004-on



T/L Transmission Oil Dipstick

Hand-operated dipstick features an engraved logo and chrome finish. Easily installs on all 1987-99 Evolution 1340 models and 1999-06 Touring, 2000-06 Softail and 1999-05 Dyna Twin Cam models. Will not work with oil pump covers OEM# 66394-93 or 66088-96 or hydraulic clutch.

64309 37123-98A



Chrome Transmission Vent Canister

Accepts 5/16" or 3/8" hose.

59523



Chrome Trans & Oil Drain Magnetic Plug

Fits 2000-on BT with 1/2-13 thread. Replaces 60328-98A.

- 72295** Custom dome head
- 72296** Stock style

Transmission Belt Pulleys

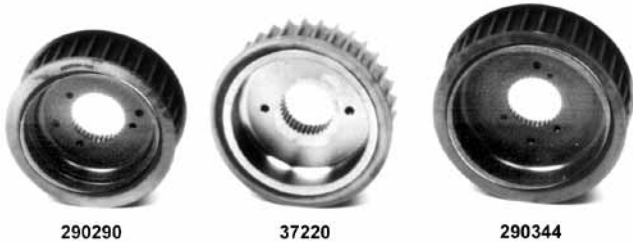

Transmission Drive Belt Pulleys-USA-5 Speed

PCP	OEM #	Tooth	Type	Model
290290	--	29T (Andrews)	Power	BT 1985-93
290294		29T (Andrews)	Power	BT 1994-06
290300		30T (Andrews)	Power	BT 1985-93
290304		30T (Andrews)	Power	BT 1994-06
37220	40210-85D	32T (Topline)	Stock	BT 1985-E94
65505	40250-94B	32T (Topline)	Stock	BT L94-06
290340	--	34T (Andrews)	Overdrive	BT 1985-93
290344		34T (Andrews)	Overdrive	BT 1994-06
3565	--	33T (Karata)	Overdrive	BT 1994-06
65509	40256-89	27T (Topline)	Stock	XL1986-90
65507	40202-91B	29T (Topline)	Stock (1200)	XL 1991-03
65508	40285-91B	27T (Topline)	Stock (883)	XL1991-03



BDL Evo Transmission Pulley

Light weight 356T6 aluminum transmission pulleys are about 1/3 the weight of stock pulleys which will extend the life of the 5th gear bearing and increase horsepower transfer to the rear wheel. The steel insert is gear cut to provide maximum bonding with aluminum when cast. The pulleys are hard anodized and include a spacer, seal and retaining plate with screws.

Evo BT 1985-06 5 Speed

PCP	BDL	Description
76406	TP-29	29T
76407	TP-30	30T
76408	TP-31	31T
76409	TP-32	32T (stock)
76410	TP-33	33T
76411	TP-34	34T

Evo XL 1992-99

PCP	BDL	Description
76412	TPS-28	28T
76413	TPS-29	29T
76414	TPS-30	30T



5 Speed Front Belt Pulley Lock Plate & Nut Kit

Kit includes: 2 allen screws (35211-91), sprocket lock nut and lock plate (40251-92).

16258 Kit BT 1992-06, XL 1991-on

13741 Lock plate only (each)



BT 5 Speed Transmission Pulley 1985-on

Stock style, steel, replacement pulleys. Stock size is 32T.

Imported

PCP BT 5 Speed 1985-93

37221 30T

37222 32T (40210-85B)

37223 34T

PCP BT 5 Speed 1994-06

37224 32T (40250-94)

Pulley Indexing 'Mega' Nut

Nut allows drilling and tapping for additional set screw locations.

12629



Stepped Inner Primary Bearing Race

Fits 1991-05 BT. Race features an extra step on the inside diameter that acts as a stop on the transmission mainshaft. When the race is pressed on the shaft the step will not allow the race to move inward toward mainshaft seal.

11905

Andrews BT Trans Belt Pulleys



More teeth on pulleys means higher MPH and less RPM. Fewer teeth means higher RPM and more power than a stock 32 tooth pulley. Pulleys are available to fit all EV80, Twin 88 and Twin 96 transmissions. Pulleys have tooth counts of 29, 30, 31, 33 & 34 for 5 speeds and 30 or 34 for new 6 speeds.

**Note: All 2007-10 Twin 96 and 2006 Dynas MUST use the new part number pulleys.
Pulleys made for 5 speed transmissions will not fit HD 6 speed transmissions.**

Overdrive Belt Pulleys

34 Tooth Sprockets (6% less RPM)
(180 RPM drop in engine RPM @ 60 MPH)

PCP Application

290346 2006 Dyna and all 2007-10

290344 1994-06 All Big Twin

290340 1985-93

33 Tooth Sprockets (3% less RPM)

290334 1994-06 All BT (not 06 Dyna)

290330 1985-93

Power Pulleys

30 Tooth Sprockets (6% more RPM)

290306 2006 Dyna and all 2007-10

290304 1994-06 All Big Twin

290300 1985-93

29 Tooth Sprockets (9% more RPM)

290294 1994-06 All BT (not 06 Dyna)

290290 1985-93

Power Pulleys

Fits all EV80 and Twin 88 5 and 6 speed transmissions.

31 Teeth Sprockets (3% more RPM)

290314 1994-06 All Big Twin

290310 1985-93

Note: Pulleys for '06 Dyna and all '07-10 Twin 96's are only available with 30 & 34 teeth.

Andrews sprocket pulleys match 1994 style design. This arrangement has the advantage of 50% longer internal spline length compared to the early design. 1994 style pulleys will fit both early (1985-93) and late transmission shafts. Overall belt drive ratio changes of 3%, 6% or 9% are very noticeable to a rider! **All 1985-93 pulley kits include new style spacer, lock ring, retainer bolts and seals. Pulley kits for 1994-on must use original stock seal and lock ring.**

Sprocket Tooth Counts & Ratios 1994-2006

(36T clutch-25T engine sprocket, 5 Speeds)

Trans.	R/Wheel	Overall
29	70	3.48
30	70	3.36
31	70	3.25
32 (Stock)	70	3.15
33	70	3.05
34	70	2.96
1995 Softail		
29	65	3.23
30	65	3.12
31	65	3.02
32 (Stock)	65	2.93
33	65	2.83
34	65	2.75

Sprocket Tooth Counts & Ratios 1985-1993

(37T clutch-24T engine sprocket)

Trans.	R/Wheel	Overall
29	70	3.72
30	70	3.60
31	70	3.48
32 (Stock)	70	3.37
33	70	3.27
34	70	3.17
1993 Softail		
29	61	3.24
30	61	3.13
31	61	3.03
32 (Stock)	61	2.94
33	61	2.85
34	61	2.76

Belt Drive Sprockets- Installation Notes:

Installing a transmission pulley with more or less teeth than stock requires adjusting the rear axle forward (for more teeth on sprocket) or backwards (for less teeth on sprocket).

Rear axle position adjustment for each one tooth change on transmission sprocket = +/- .125 inches (3.2mm)

Rear axle position adjustment for each one tooth change in belt length = +/- .280 inches (7.1mm)

If there is not enough axle adjustment at the rear frame, it may be necessary to use a belt with more or less teeth than the stock belt.

Andrews BT 5-Speed

5 Speed Transmission Gears BT

The 5 speed gear box has actually been around for a few years but the growing number of modifications for the EV 1340 has created a lot more interest in it. In addition to close ratio first gears, Andrews Products also makes replacement gears for 1st, 2nd, 3rd, 4th and 5th gears. As with the close 1st gears, all 5 speeds are made from high nickel alloy and heat treated and shot peened to give maximum durability and strength. Also, where applicable, lead-in ramps have been machined into most gears to improve shifting and reduce wear on drive dogs and drive slots.

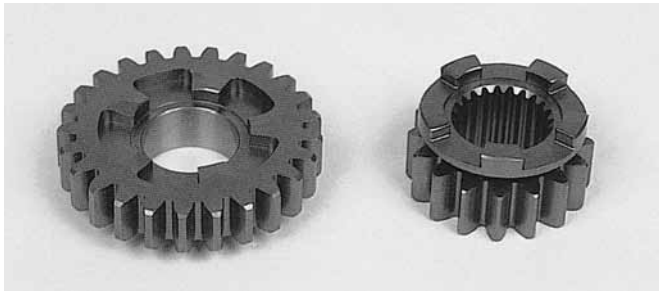

3.24 Stock Ratio 1st Gears

High nickel steel replacement 1st gears with lead-in ramps for quicker, more positive shifting.

296125 35025-79 1st main 18T
296120 35622-79A 1st counter 31T

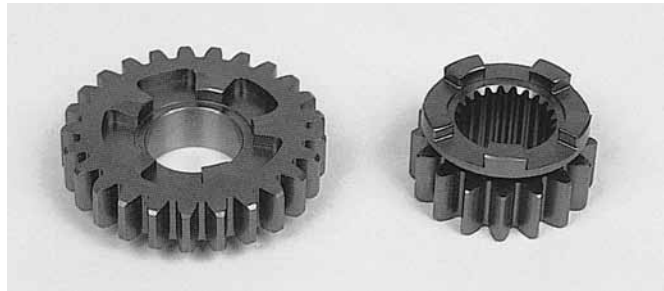

2.94 Close Ratio 1st Gear Set

2.94 1st gears provide true close ratio shifting into 2nd. At peak, RPM these gears add 5 mph of usable 1st gear. Made with lead-in ramps for quicker, more positive shifting.

296110 2 pieces

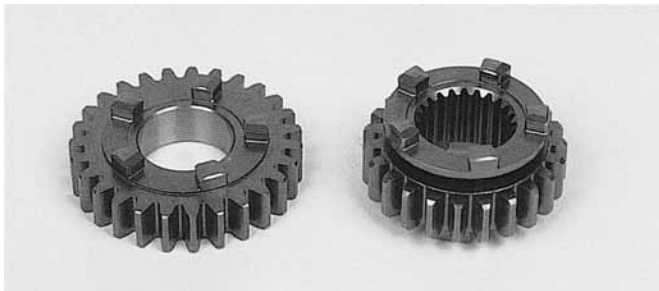

Stock 2nd and 3rd Gears

High nickel steel parts with lead-in ramps for quicker, more positive shifting. All drive edges are shot peened for greater wear resistance.

296220 35026-79A 2nd main, 3rd counter
296330 35027-79A 3rd main, 2nd counter

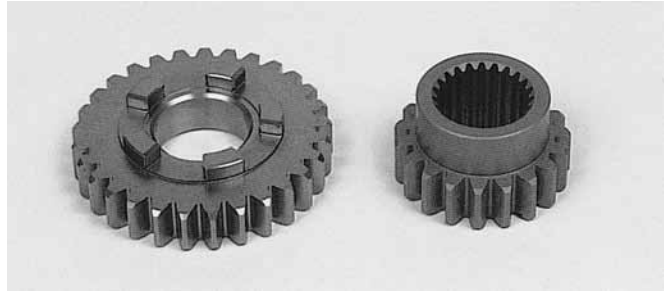

Stock 4th Gears

296445 4th main gear, high nickel steel and shot peened with lead in-ramps. Replaces 35028-79.

296440 4th counter gear Replaces 35625-79A (1987-on) and also the gear and spacer used in all earlier 5 speeds. Gear also uses high nickel steel material

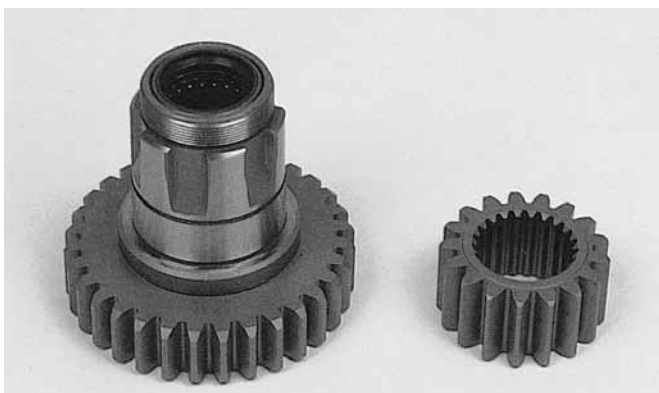

Stock Main Drive Gears (Chain Drive)

High nickel steel parts with mainshaft gears made as one piece for maximum strength. Main drive gear also has lead-in ramps for quick positive shifting.

296550 35029-79 Main drive-chain
296555 35626-79A Counter drive gear



Stock Main Drive Gears (Belt Drive)

High nickel steel parts for maximum strength. Main drive gear also has lead-in ramps for quick positive shifting.

296585 35029-85 Main drive-belt
296591 35029-91 Main drive-belt
296555 35626-79A Counter drive gear

Andrews 5 Speed

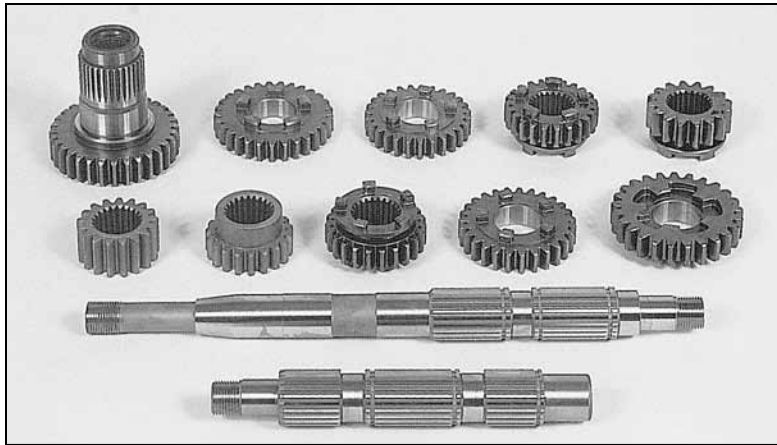

Complete 5 Speed Gear Sets

Transmission gear sets for 5 speed EV80 bikes are available as complete kits. Each kit includes the following parts:

- First gears main & counter 2 pcs
- Second gears (counter and main) 2 pcs
- Third gears (counter and main) 2 pcs
- Fourth gears (counter and main) 2 pcs
- Fifth gears (counter and main) 2 pcs
- Countershaft 1 pce
- Mainshaft 1 pce

- 296085** Belt drive 1985-89
- 296090** Belt drive 1990 only
- 296091** Belt drive 1991-06

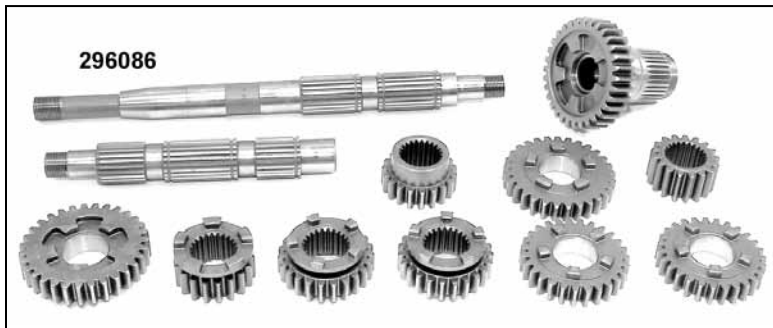

Andrews BT 5 Speed Trans Gear Sets

- | PCP | Stock Ratio |
|---------------|--------------|
| 296086 | 3.24 1985-89 |
| 296092 | 3.24 1990 |
| 296093 | 3.24 1991-06 |

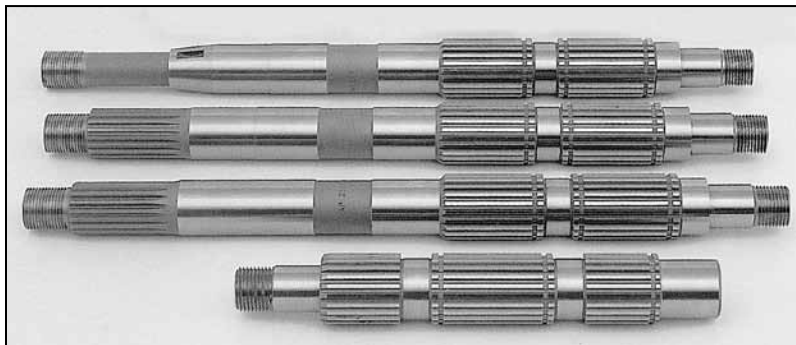

BT 5 Speed Transmission Shafts

Replacement trans shafts are made from high nickel steel with aircraft quality heat treatments.

- 296850** 35042-85 Belt drive mainshaft 1985-89
- 296900** 35042-90 Belt drive mainshaft 1990
- 296910** 35042-91 Belt drive mainshaft 1991-06
- 296700** 35632-79 Countershaft all 1979-06

Calculating Internal Transmission Gear Ratios

Since we get many questions regarding transmission gear ratios, a table of values for EV-80 transmissions is shown below along with an explanation of how the actual numbers are determined. The internal ratio (in any gear) is a combination of the speed gear ratio and the main drive gear ratio. The numbers below are the numbers of teeth on each matching pair of gears.

Gear	Main Drive	Speed Gear	Overall Ratio	5 RPM Drop	MPH per 1000 RPM
1 Stk	32/17	31/18	3.24	32	6.81
1 Close	32/17	25/16	2.94	25	7.50
2	32/17	27/23	2.21	27	9.99
3	32/17	23/27	1.60	23	13.79
4	32/17	19/29	1.23	19	17.94
5	32/17	Direct drive	1.00	---	22.07

To calculate the internal gear ratio in 2nd gear for example, multiply 32/17 by 27/23= 32/17 x 27/23= 2.21

To calculate mph per 1000 engine RPM: (assuming a 25" diameter rear wheel and a stock 3.37 final drive ratio);
 $(25 \times 3.14159) / 12 \times (1000 / (3.37 \times 60)) \times (3.0 / 4.4) = 22.07$ mph per 1000 engine RPM (in 5th gear)

To calculate MPH per 1000 engine RPM in 3rd gear: Divide 22.07 by 1.60
 $(22.07 / 1.60) = 13.8$ mph per 1000 engine RPM (in 3rd gear)

BT 5 Speed 1980-06

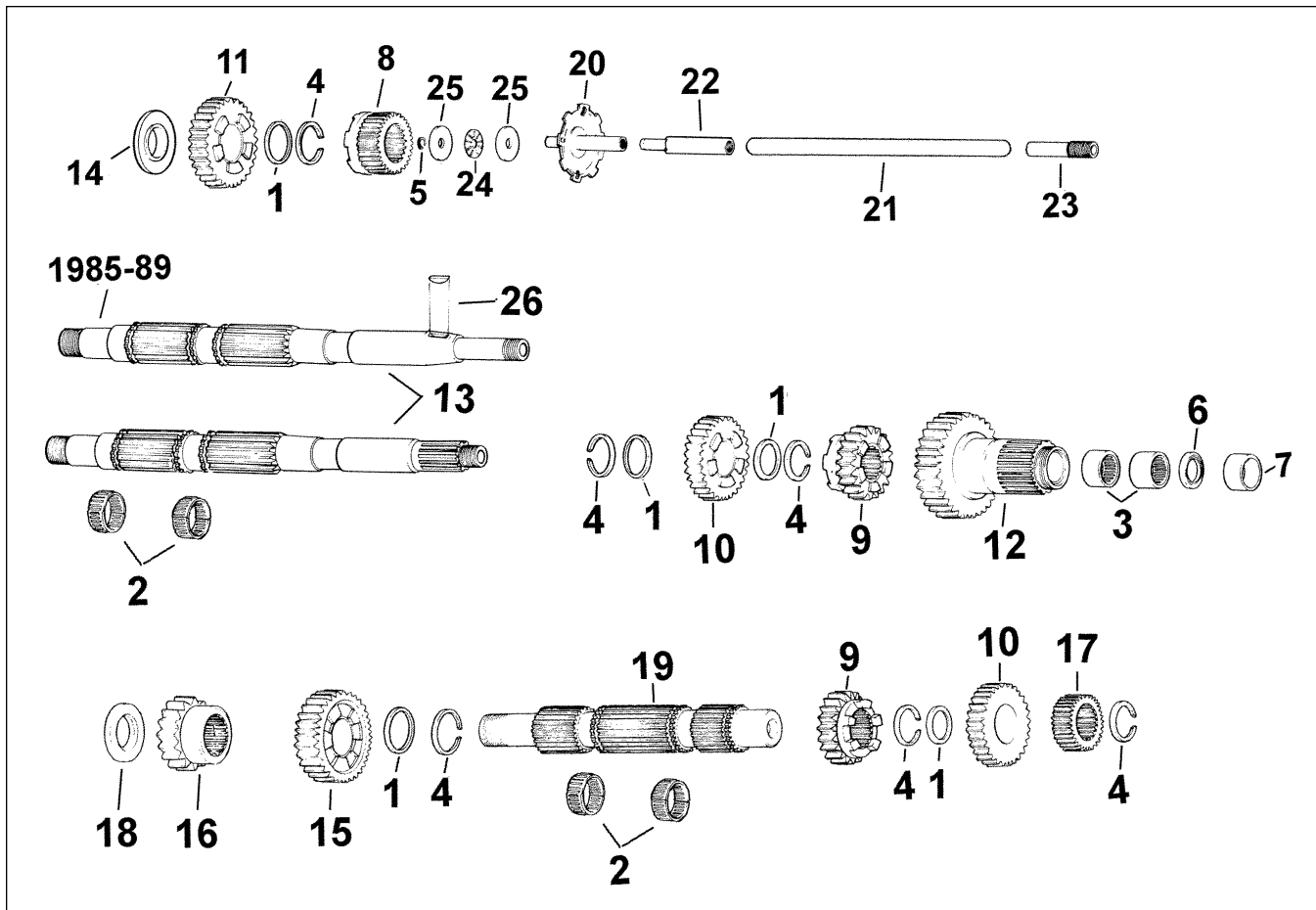

Big Twin 5 Speed Gears 1980-06

#	PCP	OEM	Description	#	PCP	OEM	Description
14	11515	35064-79	Spacer, mainshaft	14	11515	35064-79	Spacer, mainshaft
15	36017	35622-79C	1st Gear countershaft	15	36017	35622-79C	1st Gear countershaft
16	36018	35625-79B	4th Gear countershaft FXST, Dyna to 1995	16	36018	35625-79B	4th Gear countershaft FXST, Dyna to 1995
					36019*	35625-94	4th Gear countershaft FLT 95-06, FXST 1996-06
17	36020	35626-79B	5th Gear countershaft FXST, Dyna to 1995	17	36020	35626-79B	5th Gear countershaft FXST, Dyna to 1995
					36021*	35626-94	5th Gear countershaft FLT 95-*, FXST 1996-06
17A	11517	35628-79	Spacer 1980-86 only	17A	11517	35628-79	Spacer 1980-86 only
18	11516	35629-79	Spacer	18	11516	35629-79	Spacer
19	36022	35632-79	Countershaft	19	36022	35632-79	Countershaft
20	16559	37069-90	Pushrod end 1991-06	20	16559	37069-90	Pushrod end 1991-06
21	16544	37088-79	Pushrod 1980-E84	21	16544	37088-79	Pushrod 1980-E84
					16547	37088-84	As above, L1984
					16550	37088-85	As above, 1985-86
					16551	37088-87	As above, 1987-89
					16558	37088-90	As above, 1990-06
22	16543	37089-79	Pushrod right side 1980-E84	22	16543	37089-79	Pushrod right side 1980-E84
					16546	37089-84	As above, L1984-89
23	16545	37090-79	Pushrod, left side 1980-E84	23	16545	37090-79	Pushrod, left side 1980-E84
					16548	37090-84A	Pushrod end, left side L84-90
					16560	37090-84A	As above 1990-97
					16561		As above 1998-06
24	15618	37312-75	Bearing 1975-84	24	15618	37312-75	Bearing 1975-84
25	11518	37313-80	Thrust washer (5 pack)	25	11518	37313-80	Thrust washer (5 pack)
26	10311	37523-85	Key, m/shaft clutch 85-89 (10 pk)	26	10311	37523-85	Key, m/shaft clutch 85-89 (10 pk)

*High Contact Gears can only be used with a matching gear

BT 5 Speed Housing 1987-06

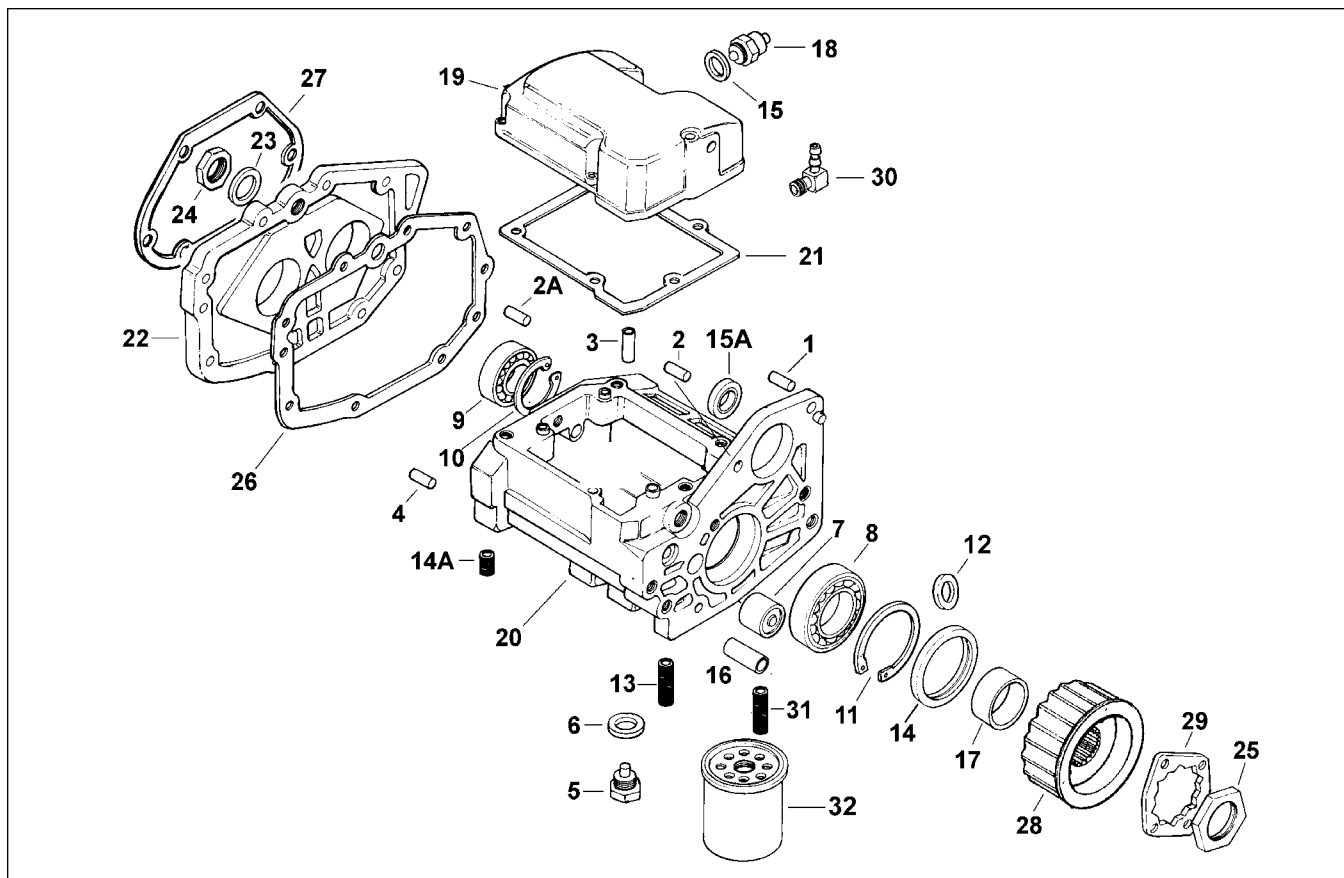

5 Spd Trans Housing FLT, FXR, & FXST 87-06

For more specific model fitment consult an OEM parts manual. **Sold each unless package quantity noted.**

#	PCP	OEM	Description	#	PCP	OEM	Description
1	10107	335	Dowel pin (5 pk) 1987-88	17	11538	33334-85	Sprocket spacer 1987-E94 all
	10109	337	Dowel pin (10 pk) 1987-92 all		18006	33344-94	Sprocket spacer L1994-on all
2	10113	375	Dowel pin 87-94 all, -96 softail (10)	18	289	33900-59C	Switch, neutral indicator
3	10119	609	Pin 1987-on (10 pk)	19	45511	34468-86A	Chrome cover 1987-99 Softail FLHTC/U 1995-97
4	10123	634	Split pin 1987-on (10 pk)	20	36805	34730-88	Housing FLT, FXR 1988
5	10616	722A	Plug 1987-92 FLT, 1987-94 FXR		36806	34730-89C	Housing FLHS 89-91, FXR 89-93
	10613	739A	Magnetic plug 1993-on Softail		36807	34703-92	Housing, B/wrinkle FXLR 1993-94
6	16300	6007	Washer FLT 87-92, FXR 87-94 (10)		36801	34731-89	Housing Softail 1989-90
7	15605	8977	Needle Bearing 1987-06 all, FXST/FXR 1993-on		36803	34732-96	Housing b/wrinkle Softail 1996-99
8	15707	8996A	Ball bearing, mainshaft, left side 1987-06 all, FXST 1993-96	21	25126	34904-86	Upper cover gasket (10 pk)
9	15708	8998	Ball bearing 1987-98		79336		As above, James (10 pk)
	15745	8992A	Bearing trap door 1999-on	22	36218	35258-87C	Bearing housing FXST 87-99 B/W
10	11014	11020	Retaining ring 1987-93 all (10 pk)		36220	35260-90C	Bearing housing black FXLR/FXDL/ WG 1990-on, FXST 1999-on
	11108	35021-89	Retaining ring 1994-98 all (10 pk)		36222	35251-93C	Bearing housing, silver 93-07 FLHT
	11118	35087-99A	Retaining ring, bearing 2007 FLT		36223	35252-93B	Bearing housing, blk 93-07 FLHTC
11	11040	11161	Retaining ring 1987-92 all, FXST/FXR 1993-on	23	11539	35076-79	Spacer 1979-on all (10 pk)
	11000	10998	Retaining ring 2007 FLT (5 pk)	24	12553	35078-79	Nut, m/shaft & c/shaft all (pr)
12	14528	11165	Quad seal 1987-on (10 pk)	25	12554	35211-36	Nut, sprocket 1936-90 all
	79039		As above, James (10 pk)		12602	35211-91A	Sprocket lock nut 1991-06 all
13	10806	11733	Stud FXST 1987-on	26	79355	35652-79A	Gasket, bearing housing (10 pk)
14	14021	12050	Oil seal, mainshaft left side, 87-92 FLT, 87-E94 FXST/FXR		79573	35653-98A	Gasket, bearing housing (5 pk)
	79508	12067A	Oil seal m/s left side 95-06 (ea)	27	79360	36801-87C	Gasket, right side cover (10 pk)
14A	10050	24557-87	Threaded insert FLT, FXR 87-92 (5)		79361		James, as above w/silicone (5 pk)
15	79310	33043-80	Washer, neutral switch (10 pk)	28	37220	40210-85D	32T Belt pulley 1985-E94
15A	14022	12051	Oil seal, trans-starter 84-89 (5 pk)		65505	40250-94B	32T Belt pulley L1994-06 all
16	11537	33114-79	Spacer 87-92 all, FXST/FXR 93-on	29	13741	40251-92	Pulley lock plate 1992-on all
				30	10521	62375-57	Fitting, upper cover
				31	10051	26352-95A	Fitting, filter brkt. 1985-on (each)
				32	2500	63796-77A	Chrome oil filter FXST 1987-on
					3841	63806-80T	Black oil filter as above

BT Housing 1980-86

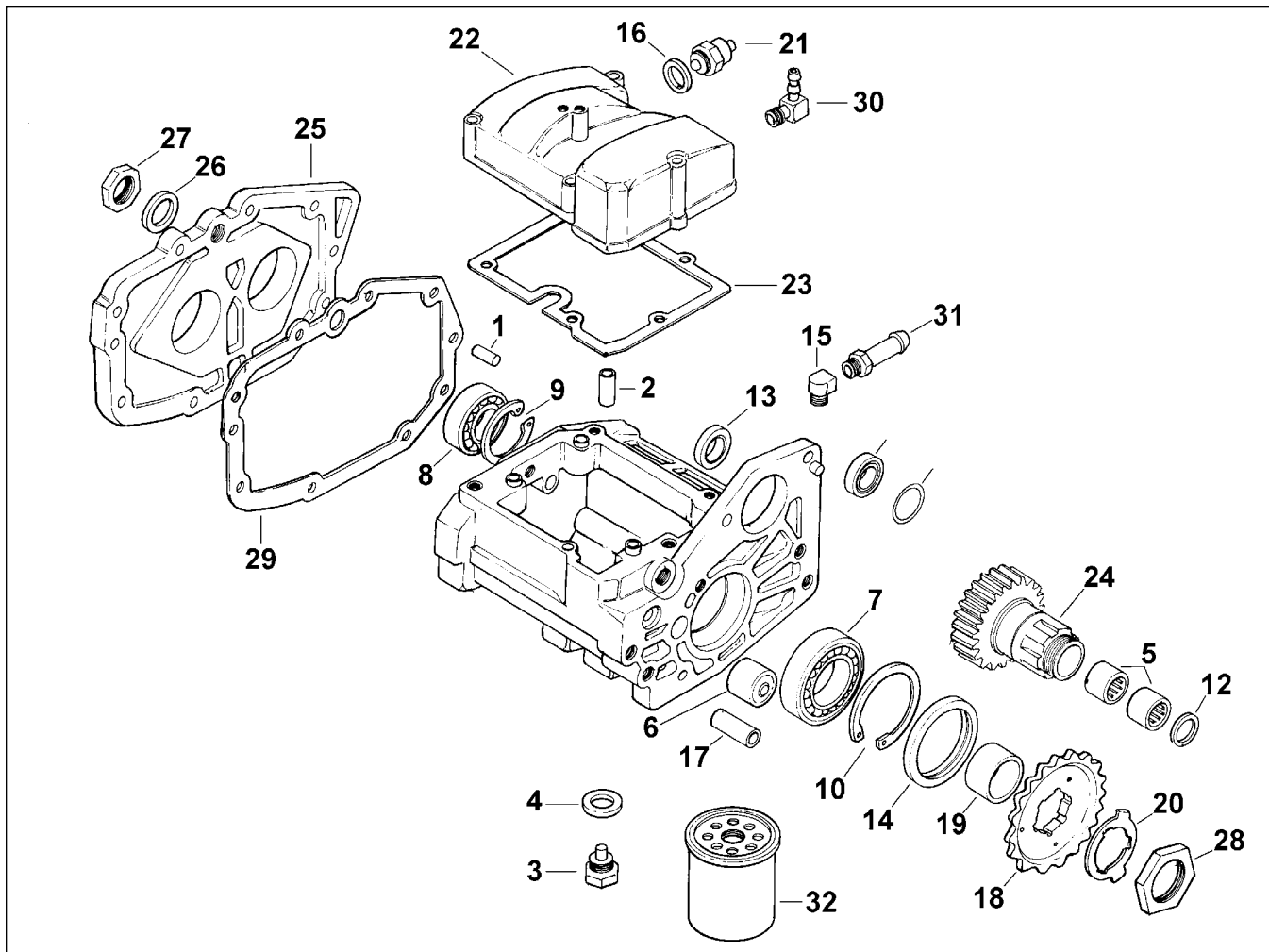

Transmission 5 Speed Housing 1980-86

Sold each unless package quantity noted.

#	PCP	OEM	Description
1	10113	375	Dowel pin (10 pk)
2	10119	609	Pin (10 pk)
3	10616	722A	Magnetic drain plug
4	16300	6007	Nylon washer (10 pk)
5	15602	8904	Needle bearing main gear 1980-86
6	15605	8977	Needle bearing 1980-E84
7	15706	8978	Ball bearing 80-E84
	15707	8996	Ball bearing L84-86
8	15708	8998	Ball bearing
9	11014	11020	Retaining ring (10 pk)
10	11028	11057	Retaining ring 80-E84
	11040	11161	Retaining ring L84-on
11	14527	11162	O-ring m/shaft right side 1982-86 (10)
12	14011	12013A	Seal, main drive gear 1985-90 (5 pk)
	79060	12013A	As above James (5 pk)
13	14017	12043	Seal, starter shaft 1980-E84 (5 pk)
	79073	12043	As above, James 1980-86 (5 pk)
	14022	12051	Seal, starter shaft L1984-88 (5 pk)
14	14018	12044A	Oil seal mainshaft 80-E84
	79075	12044-A	As above, James (each)
	14021	12050	Oil seal mainshaft L84-E94
15	10520	26338-68	Fitting, oil filter hose 80-92 (5 pk)

#	PCP	OEM	Description
16	79310	33043-80	Gasket, neutral switch, 80-on all (10)
17	11537	33114-79	Spacer
18	3621	33336-83	22T Sprocket 80-85
	3622		23T Sprocket
	3623		24T Sprocket
19	31091	33334-79	Spacer, sprocket 80-84
20	13717	33335-79	Lockwasher, sprocket 80-83 (5 pk)
21	289	33900-59	Neutral switch
22	4340	34466-82	Chrome upper cover 82-86
23	79335	34904-79	Gasket, upper cover 79-85 (10 pk)
24	296550	35029-79	Andrews main gear 1980-E84
26	11539	35076-79	Spacer (10 pk)
27	12553	35078-79	Nut, mainshaft & countershaft (pr)
28	12554	35211-36	Nut, sprocket
29	79355	35652-79	James bearing housing gasket (10)
30	10521	62375-57	Fitting, upper cover 82-on
31	10575	63533-41	Fitting, oil filter hose (5 pk)
32	2500	63796-77	Chrome oil filter
	3841	63805-80	Black oil filter

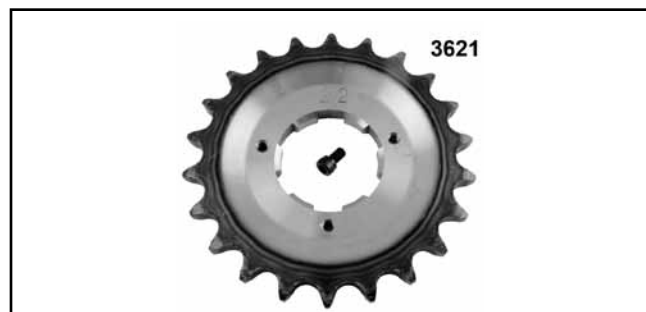

BT Shifter 1980-00

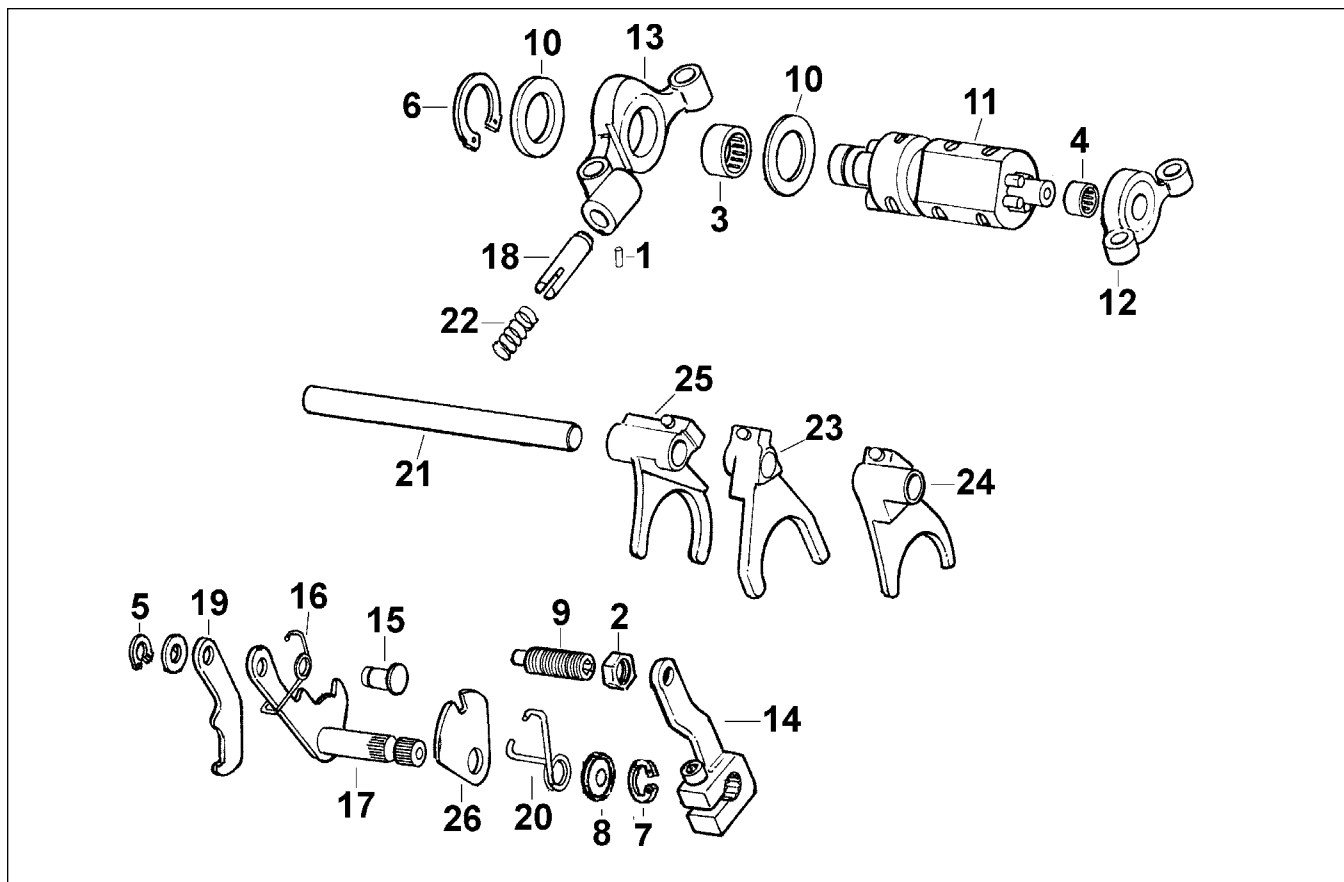

Big Twin 5 Speed Gear Shifter 1980-00

Sold each unless package quantity noted.

#	PCP	OEM	Description	#	PCP	OEM	Description
1	10103	601	Roll pin (10 pk)	12	37106	33326-79A	Support, left shifter cam
2	12501	7515	Jam nut (10 pk)		31045		As above billet, Jims
3	15627	9114	Needle bearing	13	37112	33332-79	Support, right shifter cam
4	15628	9115	Needle bearing	14	36131	33715-85A	Lever, shifter rod 1985-96
5	11011	11016	Retaining ring (10 pk)	15	10136	34082-79	Pin, shifter shaft lever
6	11032	11083	Retaining ring (10 pk)	16	13179	34083-79	Spring, shifter shaft lever
7	11036	11150	Retaining ring (10 pk)	17	37154	34084-86A	Lever, shifter shaft 1986-00
8	14019	12045	Seal (5 pk)	18	37115	34085-79A	Cam follower 1980-00
9	37150	33119-79B	Adjusting screw, shifter arm	19	37117	34086-79	Pawl, shifter cam 1980-00
10	11580	33205-80	Thrust washer .017 (5 pk)	20	13180	34087-79A	Spring, shifter shaft 1980-00
	11581	33206-80	As above, .020 (5 pk)	21	36136	34088-79	Shaft, shifter fork 1980-86
	11582	33207-80	As above, .022 (5 pk)		37200	34088-87	Shaft, shifter fork 1987-00
	11583	33208-80	As above, .025 (5 pk)	22	13181	34089-79	Spring (5 pk)
	11584	33209-80	As above, .028 (5 pk)	23	37151	34191-79E	Shifter fork 1980-06
	11585	33210-80	As above, .031 (5 pk)	24	37152	34193-79E	Shifter fork 1980-06
	11586	33211-80	As above, .035 (5 pk)	25	37153	34195-79D	Shifter fork 1980-06
	11587	33212-80	As above, .039 (5 pk)	26	37118	35068-79	Plate
	11588		Assortment of 8 pcs.				
11	37101	33320-79D	Shifter cam 1980-97				



5 Speed BT Trans Shift Pawl Assembly 80-00

This kit includes plate (35068-79), spring (34087-79), pawl plate (34086-79), shifter shaft (34084-86), spring (34083-79), pin (34082-79), washer (6016) and retaining ring (11016).

Assembly may be required.

37155 Preston (34084-86)

37156 Sifton

37157 VT

Big Twin 5-Speed

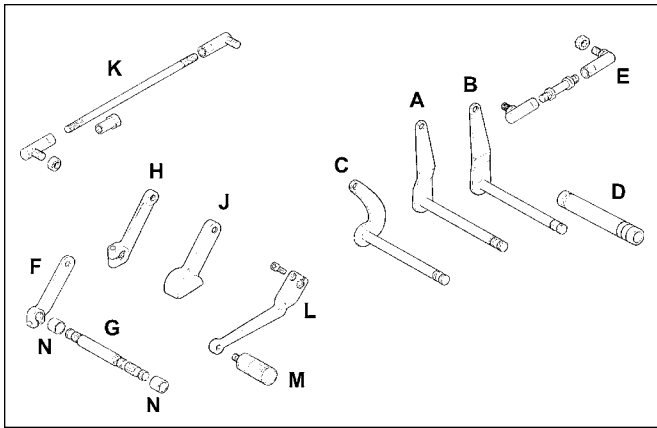

Inner Shifter Levers-5 Speed

These are splined and fit through the primary cover on 1982-88 FXR models, 1980-on FLT models have linkage on front primary cover.

PCP	OEM	#	Year/Model	Item
3094	34621-84	C	L1984-88 FXR	Lever, zinc
18556	34632-84	D	1984-on FXR	Bushing
36134	33728-82A	E	1982-94 FXR	Ball Joint, zinc
37215			1982-94 FXR	Left hand end
36132	33718-82	F	1982-08 FLT	Chrome Lever
36130	33709-82	G	1982-08 FLT	Shaft Only
36131	33715-85A	H	1985-96 All	Lever, zinc (trans)
36153	33715-85A	H	1985-96 All	Lever, chrome
45024	Chrome	J	Fits Above	Cover
36133	33719-79A	K	1980-on FLT 2001-* ST	Chrome Rod Kit, with ends
36151	33759-99B	K	1999-08 FLT	Stock zinc finish
37518	34564-90A	L	2000-on TC	Chrome shift lever
37515	33640-83		1983-on FLT/ST	Chr outer lever
37516	33895-82A		1986-92 FLST	Outer shifter arm
1147	34611-65	M	All	Black shift rubber
18623	33713-85	N	1985-00 FLT	Bushing
18643	42642-00	N	2001-08 FLT	Bushing



36133 Chrome FLT Shift Rod Kit 1980-on

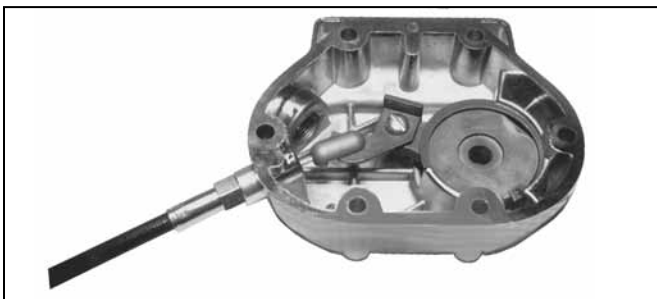

E-Z Pull Clutch Assist

Reduces manual effort required to pull the clutch lever by 40%. Mechanism fits inside transmission cover on Big Twins and the primary on Sportsters. It extends the clutch operating mechanism for improved leverage.

36125	BT's (except FXR) 1987-on and XL 4 speeds 86-90
36129	Sportster 5 speed 1991-93

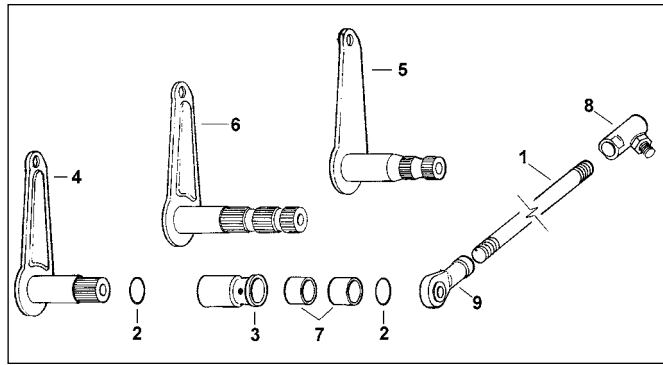

FXST, FLST Shifter Parts 1985-on 5 Speed

#	PCP	OEM	Description	Year	U/M
1	10804	11729	Cad plated rod	87-99	Each
	37211	11729	Chrome plated rod	87-99	Each
2	14562	11191	O-Ring	90-08	10 Pk
3	18611	33638-70	Bushing	85-93	Each
	18635	33708-94	As above	94-08	Each
4	37204	33660-85A	Chrome lever FXST	85-89	Each
5	37205	33660-90	As above, USA	90-06	Each
	37161		As above, Preston	90-06	Each
6	37206	33668-86A	" " "FLST/C	86-89	Each
	37207	33668-90A	" " " "	90-06	Each
7	18702	33714-90	Bushings all FXST	90-93	Pair
	18635	33708-94	Bearing sleeve	94-08	Pair
8	37203	33729-82	Zinc plated ball joint	86-96	Each
	37209	33729-82	Chrome ball joint	86-96	Each
	37225		As above, raw		
9	37202	33871-85	Cad swivel End	85-*	Each
	37208	33871-85	Chrome swivel end	85-*	Each

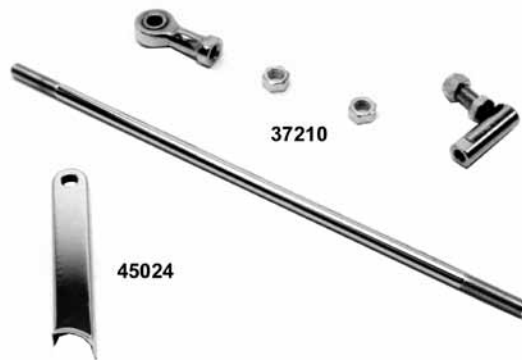

45024

Chrome FXST and Dyna Shift Linkage 1986-99

Includes Transmission Arm Cover, Rod, 2 Swivel ends, and Nuts. Arm Cover and Rod Kit also available separately.

PCP	Description
36137	Rod kit with cover
37210	Rod kit only
45024	Arm cover only



Chrome Shift Rod Kit FXR 1982-94
37213

BT 5 Speed Shifter

36177



Chrome FLT Shift Linkage Kit 1985-on

Kit includes arms, rods and swivel ends.

36177

36178



Chrome Shift Linkage Kit

Kit replaces original shift linkage on 2000-on ST models and 1980-on FLT-FLHT models.

36178 33814-98A

36179



36180

FXDWG Shift Rod Kit 1990-05

36179 Chrome

36180 Zinc

37215



36134

FXR Shift Rod Kit 1982-94

PCP Description

36134 Complete kit (zinc ball joint)

37215 Left hand end only



Shift Rod Jam Nuts

Features tapered design to cover excess rod thread. Pairs.

12653 5/16 x 24



Chrome Shifter Arm and Linkage Kit

Includes inner arm, inner shifter lever, and rod with ball and swivel ends.

36175 FXST 1906-on

36176 FLST 1990-on



BT Shifter Cam Lever Kit 2002-on

Includes all parts shown.

65399 (33386-02)

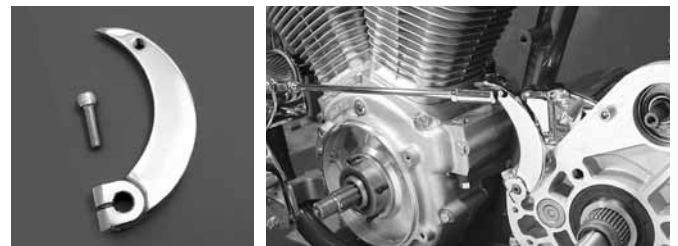

Billet BT Shift Arm

Fits 5 and 6 speed BT transmissions.

21779

BT Steel Inner Shifter Lever

PCP	Fits	Finish
36153	5 Spd 1985-96	Chrome
36131	5 Spd 1985-96	Zinc
21874	6 Spd	Chrome

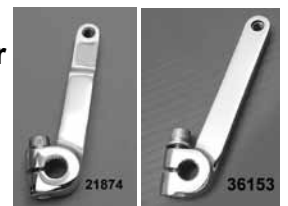

Gaskets

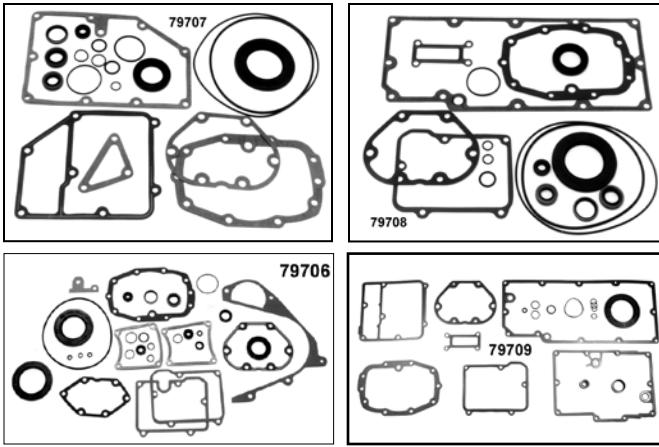

James BT Trans 5 Speed Gasket Kits

Genuine James Transmission gasket kits contain gaskets and oil seals.

PCP Application

- 79706** 1980-99 FXST (w/o oil pan) (33031-85)
- 79707** 1991-98 Dyna (33031-91)
- 79708** 1993-98 FLT, FLHS (33031-93)
- 79709** 1999-06 FLT w/bead (33031-99)

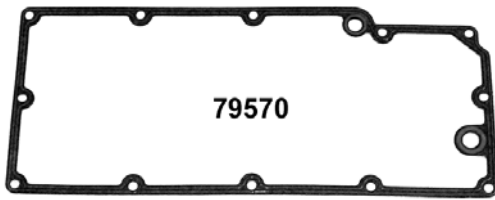
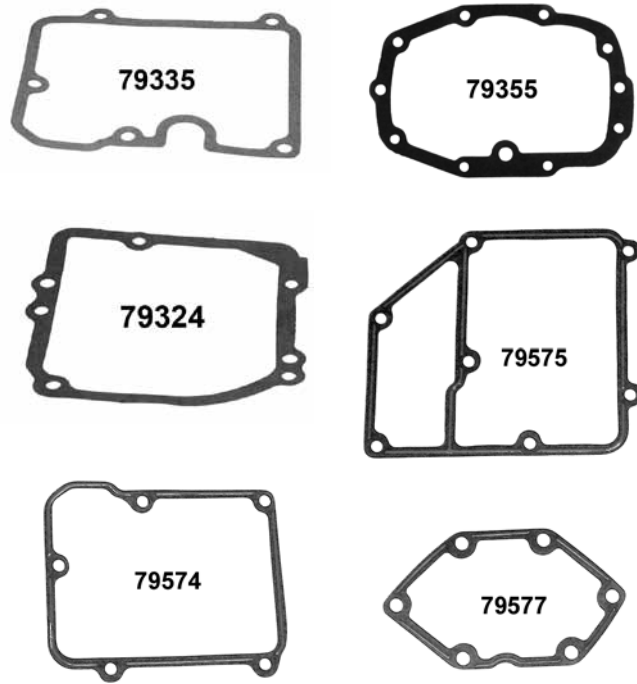

James BT Paper Oil Pan Trans Gasket

5 speed oil pan transmission housing gasket .

- 79295** FLT 1993-98 w/bead 1 side (26077-93) (10 pk)
- 79543** FLT 1999-09 TC w/bead 1 side (26077-99) (10 pk)
- 79294** Dyna 1991-98 (paper) (26072-90) (10 pk)
- 79556** Dyna 1991-98 w/bead, 1 side (26072-90X) (5 pk)
- 79570** Dyna 1999-08 w/bead, 1 side (26072-99A) (5 pk)
- 79588** Dyna 1999-08 RCM w/bead (26072-99X) (each)

James BT 5 Speed Trans Paper Gaskets

PCP Application

- 79324** Top cover FL, FXST L79-86 4 speed (34824-79) (10)
- 79340** Dyna 1991-98 top cover (34917-90) (10 pk)
- 79575** Dyna 1991-98 w/bead 1 side (34917-90-X) (5pk)
- 79572** Top cover Dyna 1999-05 bead 1 side(34917-99B) (5 pk)
- 79335** FLT, FXR 1979-85 (34904-79) (10 pk)
- 79336** FLT FXR 1986-03 (34904-86) (10 pk)
- 79574** FLT FXR 1986-03 w/bead 1 side (5 pk)
- 79355** Bearing cover FLT, FXR, Softail Dyna 1979-98 (35652-79-A) (10 pk)
- 79576** Bearing cover w/bead all 1979-98 (35652-79-X) (5 pk)
- 79573** Bearing cover w/bead 1999-06 (35653-98) (5 pk)
- 79358** Clutch release cover 1979-86 (36801-79) (10 pk)
- 79577** As above w/bead 1979-86 (36801-79-X) (5 pk)
- 79360** Clutch release cover all 87-06 (36801-87-A) (10 pk)
- 79361** As above w/bead 2 sides (36801-87-X) (5 pk)

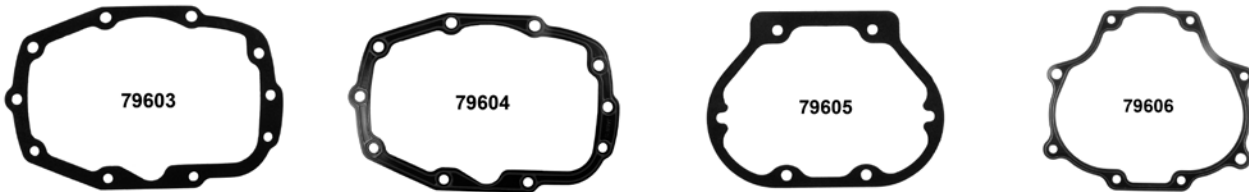

James 6 Speed Transmission Gaskets

PCP	OEM	Description	Fitment	U/M
79603	35147-03-F	Bearing cover, foamet	S/E 6 Speeds 2003-09	Each
79604	35147-03-X	Bearing cover RCM with bead	S/E 6 Speeds 2003-09	Each
79605	35148-03-F	Release cover, foamet	S/E 6 Speeds 2003-09	5 Pk
79606	35654-06-X	Bearing cover RCM with bead	FXST, Touring 2007-09 Dyna 2006-09	Each
79844	33031-05	Transmission gasket and seal kit	Dyna 2001-06 6 Speed	Kit
79845	33031-06	Transmission gasket and seal kit	Dyna 2006-09 6 Speed	Kit
79846	33031-07	Transmission gasket and seal kit	Touring 2007-08	Kit

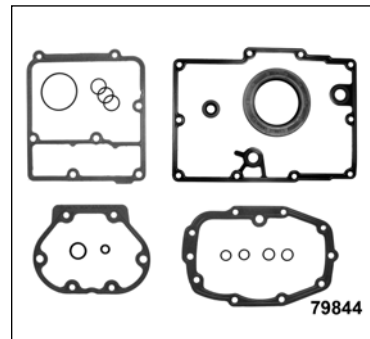



79513



Big Twin Trans Oil Seal Kits

- 79835** Trans sprocket kit for 1984-94 FLT, FXR, Dyna, and Softail (12050-K)
- 79513** Trans oil seal kit 1995-06 FLT, FXR, Softail and 1994-05 Dyna (12067-AK)
- 79840** M/shaft L/S Dyna 2006-09 (12074-K)



5 Speed Main Drive Gear Oil Seal & Spacer Kit

Big Twin kit features three lip seal and coated sprocket spacer. The coating provides superior surface lubricity and increased corrosion resistance. Fits 1994-06 as a replacement or for a ratio change on earlier models with late pulley.

15952



Magnetic Drain Plugs

- | PCP | Size | Use |
|--------------|----------|---|
| 10610 | 3/8 x 24 | BT Case plug 74 & 80 (700) (not magnetic) |
| 10611 | 1/2 x 13 | 74 & XL Trans (707) |
| 10615 | 1/4 x 18 | NPT chain cover (718) |
| 10612 | 5/8 x 18 | Oil tank & time hole (720) |
| 10616 | 5/8 x 18 | FXR drain (722A) |
| 10613 | 1/8 x 27 | NPT 1987-89 BT primary trans FXST-FXR (734, 739A) |
| 10614 | 1/8 x 27 | As above with Hex |
| 10619 | 1/8 x 27 | NPT 1990-on BT trans (739A) |
| 10618 | 1/2 x 20 | 74 & 80 Inner primary (60348-65A) |

Prevents metal particles from circulating through engine and transmission cases, oil tanks, etc.

Big Twin Trans Oil Seal

James PCP

- 79487** FLT 1985-90 rubber OD (12013) (5 pk)
- 79060 14011** FLT 1985-90 metal OD (12013-A) (5 pk)
- 79061 14012** FL, FLH, FLT, FX, FXR 65-90 (12014) (5 pk)
- 79070 14095** FLT, FXR, Softail, Dyna 91-on (5 pk) (12035-B)
- 79073 14017** FLT, FXR, FXRS 1980-86 (5 pk) (12043)
- 79074 -** FLT, FXR, FXRS 1980-86 (5 pk) (12043-A)
- 79077 14019** FLT, FXR, Softail, Dyna 80-06 (5 pk) (12045-DL) (rubber OD)
- 79491** As above w/metal OD (12045m) (5 pk)
- 79080 14021** FLT, FXR, Softail, Dyna 1984-E94 and XL 1991-94 (ea) (12050)
- 79081 14022** FLT, FXR, Softail 84-89 (5 pk) (12051)
- 79082 14024** FLT, FXR, Softail, Dyna 1984-04 (5 pk) (12052) (inner primary)
- 79084 -** FLT, FXR, Softail, Dyna 1994-08 (5 pk) (12052-F) (inner primary)
- 79086 14075** FLT, FXR, Softail, Dyna 1989-93 starter shaft (5 pk) (12053-A)
- 79507 14104** FLT, FXR, Softail, Dyna 1994-06 starter shaft (5 pk) (12066-A)
- 79508 14076**** FLT, FXR, Softail, Dyna 1995-06 trans (ea) (12067-A)
- 79066** Dyna 06-09, Touring 07-09 m/shaft L/S (12074) (ea)
- 79068** Dyna 2006-09 input/output shaft (12077) (each)
- 79363** Clutch release lever 1984-86
- 79373** Shifter shaft XL 1986-on (37101-84) (each)
- Clutch release lever Dyna 2006-09, Touring and FXST 2007-09 (37101-84B) (5)

**Note: 5 pack

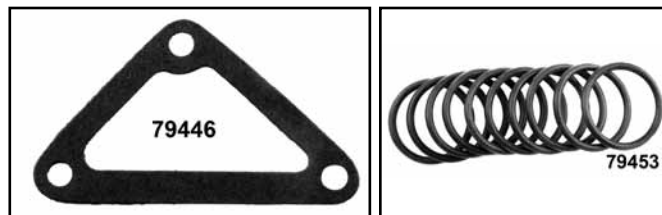

Big Twin Misc. Trans Gaskets

- 79446** Oil spout, paper 1991-98 Dyna FXDB-S (62423-90)
- 79199** Shifter washer, black nylon FXST 1990-09 (6057) (10 pack)
- 79362** Dipstick washer, plastic 1980-86 5 speed (37091-80) (10 pack)
- 79375** Drain plug seal, metal w/rubber 1980-94 BT (6007-X) (6 pack)
- 79453** Oil pan dispstick o-ring 1991-98 Dyna (62672-90) (10 pack)

BT Clutch 1984-89

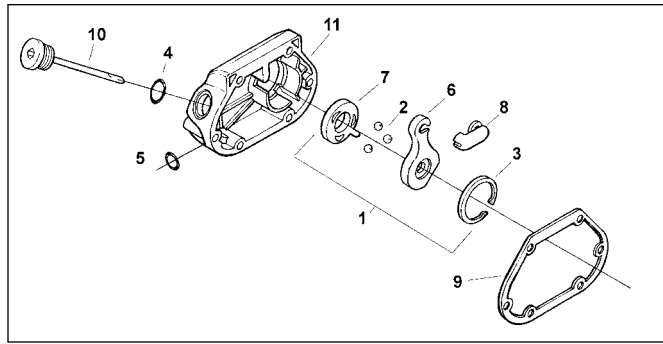
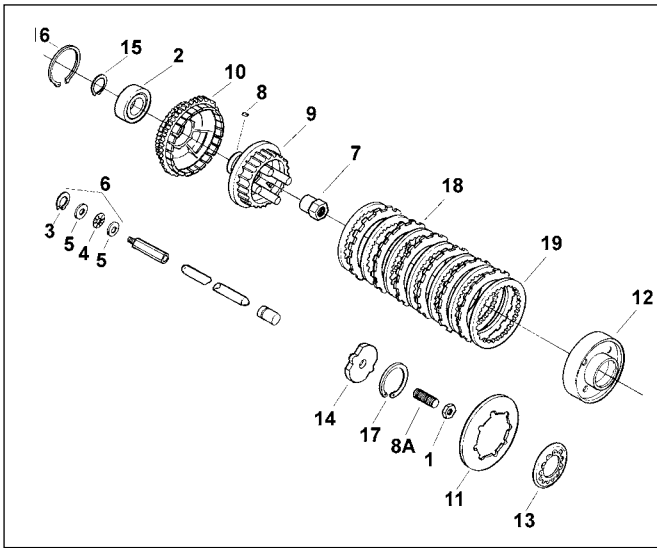

L1984-89 BT Clutch Parts

#	PCP	OEM	Description	U/M
1	12509	7848W	Lock Nut, Sprocket	10 pk
2	15716	9025A	Bearing	Each
3	11034	11096	Retaining ring	10 pk
4	15618	37312-75	Bearing	Each
5	11518	37313-80	Thrust washer	5 pk
6	4342		#3,4,5	Kit
7	12558	37496-84	Nut, Clutch hub	Each
8	10311	37523-85	Key 1985-89	10 pk
8A	10907	37537-84	Adjusting stud	Each
9	37107	37550-84A	Hub, Steel (USA) 84-89	Each
	37230		Hub, (Preston) 1984-89	Each
10	37227	37702-84A	Clutch shell 1984-E85	Each
	37228	37707-84A	Clutch shell L1985-89	Each
11	N/A	37875-86A	Diaphragm spring	
12	37110	37901-84A	Pressure Plate	Each
13	37119	37902-86B	Adj. Plate (USA)	Each
14	37111	37903-84	Release Plate (USA)	Each
	37116		Preston, as above	
15	11076	37904-84	External Ring	5 pk
16	11006	11006	Internal Ring 1986-on	5 pk
17	11080	37907-84	Retaining Ring	5 pk
18	38976	HDP-9K	Friction Plates (Barnett)	Set
19	38907	37975-84	Drive Plate (Barnett)	Each
20	38917	-	Spring Kit H/Duty	Kit

Clutch Release Kit BT 1987-99

#	PCP	OEM	Description	Year	U/M
1	37000	-	Release Kit	87-99	Kit
2	15574	8873	Ball bearing	87-*	10 pk
3	11000	10998	Retainer Ring	87-*	5 pk
4	14516	11132	O-Ring, Filler	87-99	10 pk
5	14536	11179	O-Ring Cable	87-*	10 pk
6	37100	25452-87A	Inner Ramp	87-99	Each
7	37102	25453-87A	Outer Ramp	87-99	Each
8	37104	34920-86	Coupling	87-*	Each
9	79360	36801-87B	Gasket	87-06	10 pk
10	37105	37075-87	Chromed Plug	89-*	Each
11	45508	37105-87A	Chrome Cover	87-06	Each
12	8909	--	Allen Bolts FX, FL FXST	87-*	Kit
	8912	--	Acorn Screws	87-06	Kit
	8913	--	Cap Screws	87-06	Kit

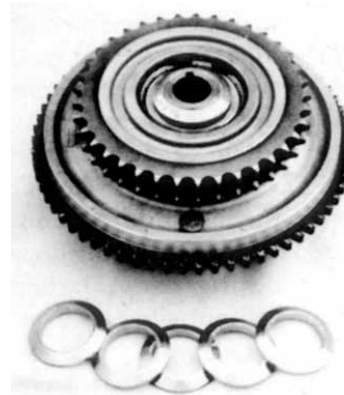

1985-90 Clutch Hub Sleeve

A reinforcement ring for hubs at the tapered end. Sleeve is pressed on with beveled side out toward inner primary, after clutch drum with bearing is set over hub, so that clutch drum and hub will be installed as one unit. Available in 2 sizes to fit OEM hubs (1) 37550-84 (2) 37550-84A. These will NOT repair a cracked hub.

16565 (1) Silver (sold each)

16566 (2) Gold (sold each)

Note: 16565 fit aluminum one-piece type hub (OEM 37550-84). 16566 fits steel two-piece type hub (OEM 37550-84A)



Clutch Hub Kit BT 1984-89

Includes updated reinforced steel center clutch hub, steel drive plate set & friction plate set.

59608

BT Clutch Pack

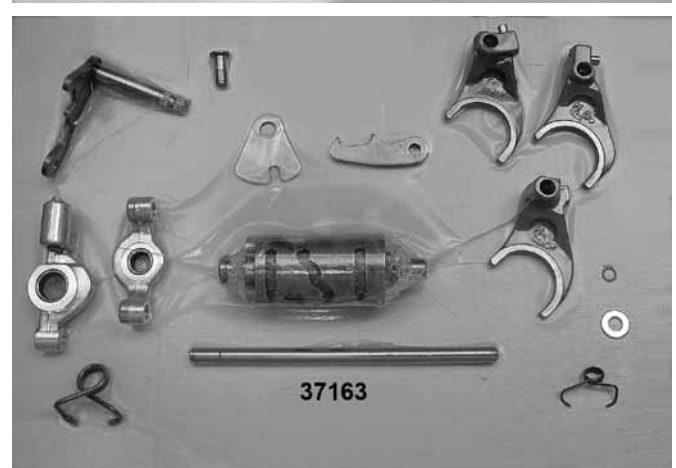
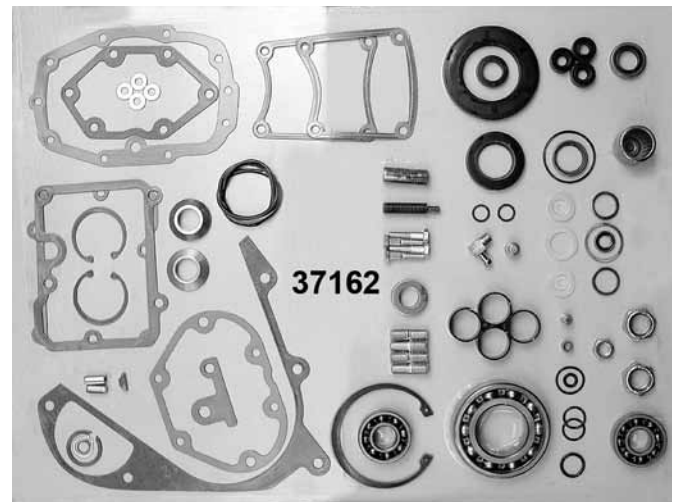

Clutch Pack Assembly 5 Speeds.

Features stock style components for a complete installation.

PCP	Fit
90101	1984-E85
90105	1985-90
90129	1991-93
90130	1994-97
90133	1998-06

BT 5-Speed Builder's Kits

PCP	Description
37162	Internal small parts kit
37163	Shift shaft drum assembly 1979-97

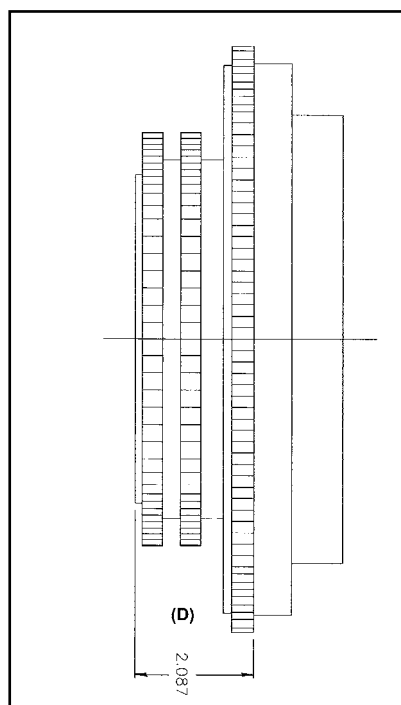

Clutch Drum and Hub Assembly

Bearing and snap ring are installed in drum. Starter ring gear dimensions shown.

PCP	Year	Offset (D)
37244	1984-E85	1.670
37245	E1985-90	2.087

BT Clutch 1990-97

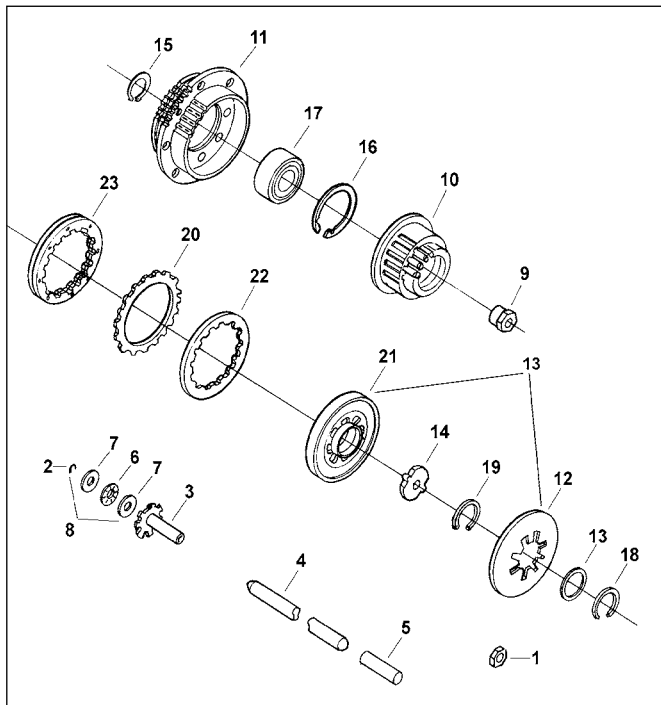

BT Evo Clutch Hub 1990-97

Replacement inner clutch hub on Big Twin Evo models 90-97. Replaces OEM 37550-90A.

37231 Preston
65400 T/L

1990-97 Big Twin Clutch Parts

#	PCP	OEM	Item
1	12509	7848W	Locknut 1990-on(10 pk)
2	11034	11096	Retaining Ring 1990-on(10 pk)
3	16559	37069-90	Push Rod End 91-on
4	16558	37088-90	Push Rod, Release 1990-97
5	16560	37090-84A	End, Rod, Left 1990-97
6	15618	37312-75	Bearing only
7	11518	37313-80	Thrust Washer (5 pk)
8	4342		Kit (2,6,7)
9	12559	37496-90	Mainshaft nut
10	65400	37550-90A	T/L clutch hub 66T 1990-97
	37231		Preston as above
11	36905	37707-90	Clutch drum w/gear 90-93 T/L
	37232		Preston as above
	65404	37707-94	T/L clutch drum 94-97 102T
	37233		Preston as above
12	38919	37871-90	Diaphragm Spring
	38005		Preston as above
13	62107	37872-90	Spring Seat
14	62108	37903-90	Release Plate
15	11077	37904-90	Retaining Ring, External
16	11079	37905-90	Retaining Ring, Internal
17	15732	37906-90	Bearing 1991-08
18	11081	37908-90	Retaining Ring, External
19	11082	37909-90	Retaining Ring, Internal
20	38872	37911-90	Plate Set (8)
21	62109	37912-91	Pressure Plate
	71035	37912-91A	Preston, as above
22	38863	37913-90	Steel Plate (each)
23	62110	37977-90	USA Spring Plate, Smooth
	38006		Preston as above



Clutch Pressure Plate BT 1990-97

71035 Preston (37912-91A)
62109 T/L as above



Clutch Hub

PCP **Year**
37234 1998-06 (Preston)
65402 2007-on (T/L)

BT Clutch 1998-06

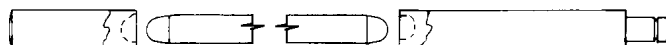

Left
(Clutch Side)

Center

Right
(Bearing Side)

Clutch Pushrods for Late Model Big Twins

U.S.A.-made 3-piece clutch pushrods to fit all 5-speed models 1984-on and 4-speed models (with diaphragm clutch) from L1984-86. Each piece is heat-treated where necessary. Sold each and in kits

PCP	OEM	Description	Kit #
All Late 1984 5-speed models			
16546	37089-84	Right end	Kit 16553
16547	37088-84	Centre piece	
16548	37090-84	Left end	
All late 1984-86 4-speed models			
16546	37089-84	Right end	Kit 16554
16549	37285-84	Centre end	
16548	37090-84	Left end	
All 1985-86 5-speed models			
16546	37089-84	Right end	Kit 16555
16550	37088-85	Centre piece	
16548	37090-84	Left end	
All 1987-89 5-speed models			
16546	37089-84	Right end	Kit 16556
16551	37088-87	Centre piece	
16548	37090-84	Left end	
All 1990 5-speed models			
16546	37089-84	Right end 1990-on	Kit 16557
16558	37088-90	Centre 1990-on	
16548	37090-84A	Left end to 1997	
All BT 1991-97			
16559	37069-90	Right side	Kit 16540
16558	37088-90	Centre	
16560	37090-84A	Left side	
All BT 1998-01			
16559	37069-90	Right side	Kit 16541
16558	37088-90	Centre	
16561	37090-98A	Left side	
Bearing Retaining Clip			
11034	11096	Fits all Big Twins L1975-on (10 Pack)	

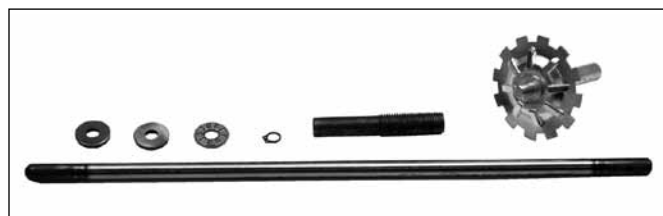

6 Speed Clutch Pushrod Kit 2006-on

Includes right and left ends for 2006-on BT 6 speed clutch.

16542 (37069-90, 37090-98, 37092-06)

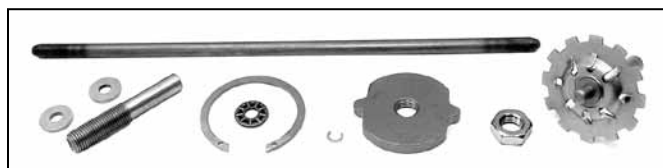

Topline Pushrod Kit

Pushrod kit is required for use with clutch assembly 37960-98B. Kit includes clutch push rod end, release plate, rod end adjuster screw and hardware.

29143 1998-06 Twin Cam 88 and BT 1340cc (37967-00)

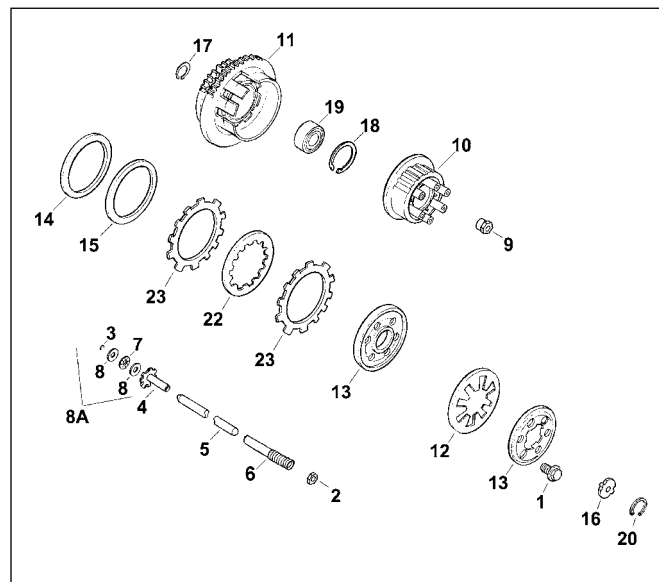

Big Twin 5 Speed Clutch Parts 1998-on

#	PCP	OEM	Item
1	24159	2980	Screw (10 pk)
2	12509	7848W	Locknut 86-on(10 pk)
3	11034	11096	Retaining ring 75-on(10 pk)
4	16559	37069-90	Pushrod end 91-06
5	16558	37088-90	Pushrod, release 90-06 (center)
	16523	37092-06	Pushrod release 2006-on
6	16561	37090-98A	End, Rod, Left
7	15618	37312-75	Bearing only
8	11518	37313-80	Thrust washer (5 pk)
8A	4342		Kit (2,6,7)
9	12559	37496-90	M/S Nut
10	65401	37550-98	Clutch hub, T/L 1999-06
	37234		As above, Preston
	65402	37554-06A	Clutch hub, T/L 2007-on
11	65411	37707-98A	Clutch shell and sprocket with 36T ring gear 1998-06 OE (not injected)
	37236		As above, Preston
	65429	37813-06	Clutch shell 2007-on
	37243	37813-06	As above, Preston
	65428	37802-04A	Clutch assembly complete 2004-06
	65420	37846-99A	As above, 37T ring gear 98-03
12	62111	37871-98A	Spring, diaphragm 1998-05
	38866		Alto, as above
	38984		Barnett, as above
	62115	37871-04	Spring, diaphragm 2004-05
	62118	37882-06	Spring, clutch 2006-on Softail
13	37242	37912-98A	Clutch pressure plate 98-10
14	62113	37883-98	Seat, damper spring 1999-on
15	62114	37884-98	Damper spring
16	62108	37903-90	Release plate 90-97
17	11077	37904-90	Retaining ring, external
18	11079	37905-90	Retaining ring, internal 1990-99
	11098	37905-00	As above, internal 2000-on
19	15732	37906-90	Bearing (ball, double row)
20	11082	37909-90	Retaining Ring, Internal
22	62116	37913-98	Steel Plates 1999-on (8 pk)
23	62117	37932-98	Friction plate kit (9 pk)

BT Clutch 1987-on

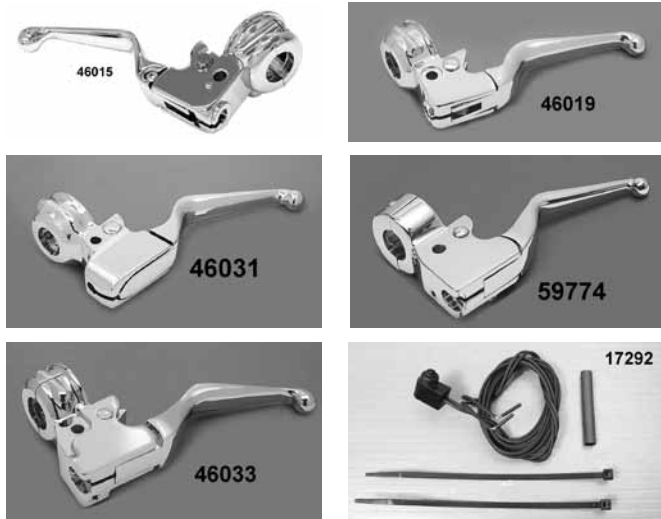

Chrome Clutch Handle Assembly 1996-on

Includes mount bracket, clamp and handle. Assembled.

PCP	Model
46015	1996-06 BT, 1996-03 XL
46019	2007-on BT
46031	2008-on Touring FLT
59774	2004-06 XL
46033	2007-on XL
17292	2007-on Switch

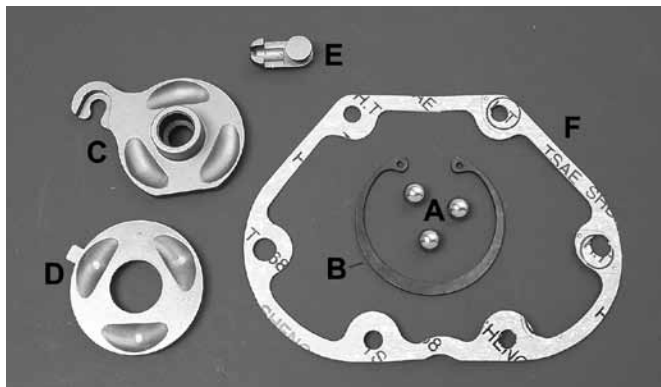

Clutch Release Kit 1987-on

For cable direct operated clutch on 5 speed models.

PCP	Application
37000	1987-99 Kit (as shown)
15574	(A) 1987-on Ball (10 pk) (8873)
11000	(B) 1987-on Retainer ring 1987-on (5 pk) (10998)
37100	(C) 1987-99 Inner ramp (25452-87)
37137	(C) 2000-on Inner ramp (25604-00)
37102	(D) 1987-99 Outer ramp (25453-87A)
37138	(D) 2000-on Outer ramp (25605-00)
37104	(E) 1987-on Coupling (34920-86)
79360	(F) 1987-06 Gasket (36801-87)
79361	(F) 1987-06 Gasket w/silicone

Sealed Clutch Drum Bearing 1985-on

For belt drive applications on Big Twins.

PCP	Years
15755	1985-90
15756	1991-06



BT Easy Starter Kits

Improves starting on high compression big inch engines through an improved starter to clutch basket gear ratio. Complete kits include a clutch basket with bearing for BT models with 66T starter ring and a 9T starter pinion gear.

PCP	Year
59350	1994-97
59351	1998-06
73741	9T Pinion gear
65409	66T ring gear



BT 5 Speed Clutch Release Kit 1987-05

Includes end rod with slinger, bearing, washers and snap ring.

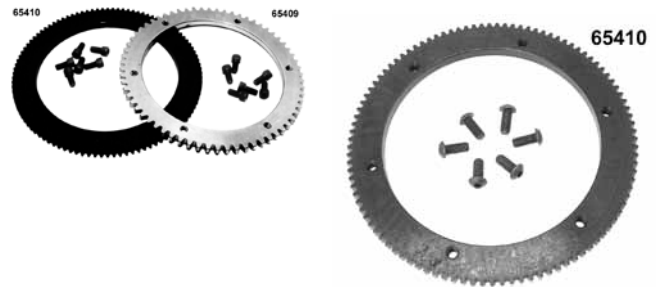

Starter Ring Gears

For replacement on stock clutch hubs only.

PCP	Description
2819	BT 1965-85 (33163-65B)(weld-on)
65409	BT 1990-93 (66T) Primo (bolt-on)
65410	BT 1994-97 (102T) Primo (bolt-on)
76076	BT 1998-06 (102T) (bolt-on)
65418	XL L1984-90
65419	XL 1991-on

BT 5 Speed Trans Housing

Delkron 5 Speed Transmission Case

These quality manufactured cases feature reinforced design for 1990-94 FXR rubber mount or FXST-FLST rigid mount applications 1989-99. Cases listed as door included; have main and countershaft bearings and shifter shaft bushings installed. Available in natural aluminum finish.



36822

Delkron FXR 5 Speed Case

PCP	Type
36822	Case w/door and bearings (no speedo pick-up)
36823	As above w/speedo pick-up

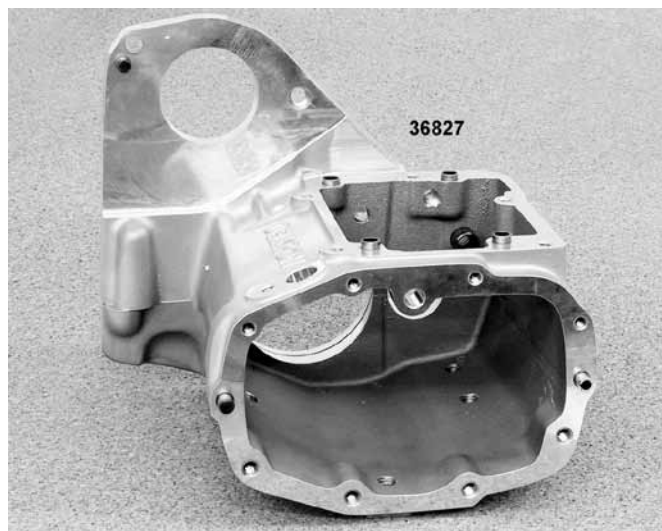

36827

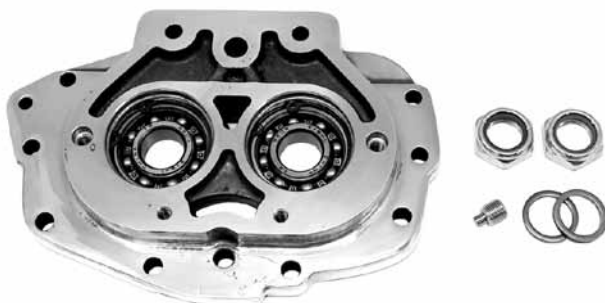

Delkron FXST 5 Speed Case

PCP	Type
36825	Case only black wrinkle 1990-on (no sensor)
36827	Case only w/speedo sensor hole 1994-on
36826	Case w/door and bearings 1990-95
36828	Case w/door, bearings and electronic speedo pick-up 1994-on

Sifton Big Billet Trans Door

Includes pressed-in bearings and appropriate retaining rings to fit 5 speed 1987-99 models.
59752



5 Speed FXST Transmission Offset Plates

These 1" offset mounting plates for 5 speed Softtail transmissions are available raw or with a chrome finish. Use these plates to assemble a wide drive swingarm or extra wide rigid frame custom bike.

71018	Chrome
71019	Raw

BT Main Drive Gear Oil Seal & Spacer Kit 94-*

Oil seal and spacer fit BT 5 speeds and feature triple lip seal and coated sprocket spacer. The coating provides superior surface lubricity and increased corrosion resistance.
15952



5 Speed Trans Oil Seal

14076	BT 1995-06 (12067A) (5 pk)
-------	----------------------------

S&S 5 Speed Housing

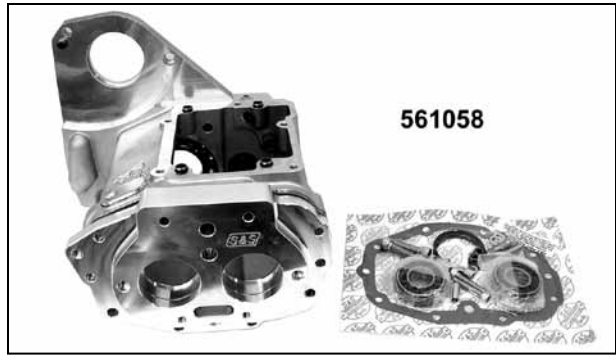

S&S 5 Speed Softail Style Trans Case Kit

S&S transmission cases for 1989-99 Evo style Softails are made from 356-T6 aluminum alloy and are CNC machined. Transmission cases are available in your choice of natural aluminum finish or black powdercoat finish. The basic case assembly includes the transmission case plus the shift lever adjustment screw, shifter shaft guide, and all studs and dowel pins required for assembly. The optional trap door kit features a CNC machined, billet trap door complete with bearings and hardware. 1986-88 models require a starter adaptor kit to be purchased separately.

Natural Black Description

- **561071** Basic case only
- 561044 561047** Case assembly w/bearing & seal kit
- 561058 561049** Complete case assembly w/trap door, bearing and seal kit



S&S Trap Doors 1987-99

PCP Description

- 561025** Trap access door only
- 561027** Trap door w/gaskets, both bearings and hardware

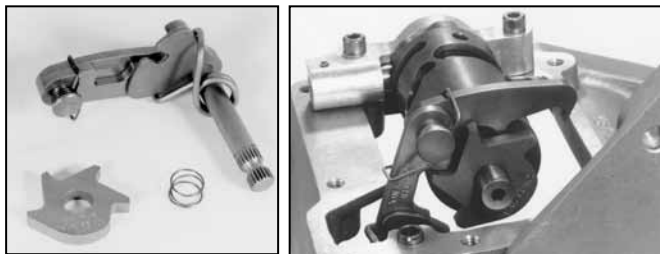

Posi-Shift by Sputhe Engineering

Posi-Shift is a positive stop mechanism that prevents miss shifts and limits the amount of rotation on each gear. Fits all 5 speeds 1989-00. Can be used on earlier 5 speeds by changing to a new style shift drum with pressed-in detent pins.
37160



S&S Starter Adapter Kit

- 561046** Includes all parts required to install a 1986-88 Softail-style starter on S&S case

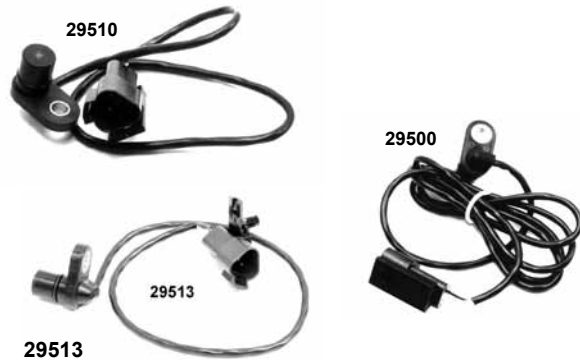

Electronic Speedo Transmission Sensor

Sending unit fits stock BT 5 speed.

- 29500** Softail 1996-99 (74437-96)
- 29501** All Softail 2000-06 and FLT 2004-06 (74430-00D)
- 29510** FLT 1995-96, Dyna 1994-05 (74420-94C)
- 29513** FLT 1997-03 (74429-97C)
- 29504** XL 1995-03 (74402-95B)
- 29538** XL 2004-on, Touring 2007-on, Softail 2007-on, Dyna 2006-on (74402-05)

BT 5 Speed Trans Housing

Made in USA Gear Boxes

These top quality cases are ready for stock gear parts. Feature stock finish. Case complete with mainshaft seal and bearing installed, countershaft bearing installed, and mount studs & roll pins.



36815



36810



36811



36831



36832

USA Trans Case FLH Models

PCP	OEM	Fits
36819	34771-01	2001 FLHTC (black)
36815	34740-94	1994-98 FLHR (black)
36816	34829-99	1999-00 FLHR/CI, FLH Touring (black)
36834	34740-02	2000-06 Touring (black)
36835	34700-07	2007-on Touring (black)

USA Trans Case Dyna Models

PCP	OEM	Fits
36810	34747-90A	1993-94 (b/wrinkle)
36811	34747-95	1995-96 FXD/WG (b/wrinkle)
36812	34746-95A	1995-99 FXD (plain)
36833	34827-99	FXD 1999-2000 (silver, polish top)
36829	34746-99	FXD 2000 (plain)
36830	34827-99	All but FXD 2000 (black)
36831	34746-01B	FXD 2001-05 (silver)
36832	34747-01B	FXDL/WG/X/XT 2001-05 (black)



BT Bearing Cover

Touring models 1993-07
36223 Black (35252-93B)



36804

USA Trans Case Softail Models

PCP	OEM	Fits
36801	34731-89	1989-90 (plain)
36803	34732-96	1989-99 (b/wrinkle)
36804	34732-00A	2000-05 not FXST/I (black)

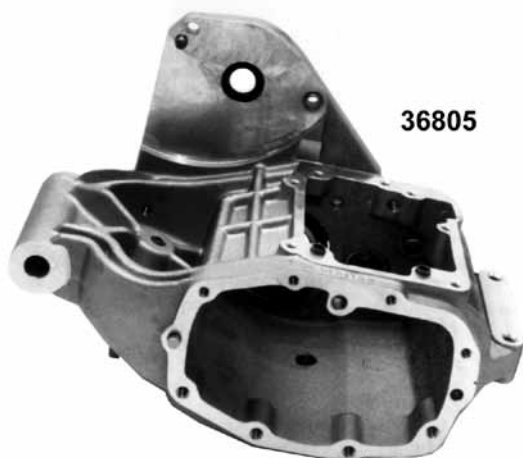

36805

USA Trans Case FXR Models

PCP	OEM	Fits
36805	34730-88	1988 (plain)
36806	34730-89C	1989-94 (plain)
36807	34703-92	1993-94 (b/wrinkle)

BT 5 Speed



Primary Chain Drive Systems

Kit includes 82 link Diamond primary chain, chain shoe adjuster assembly, clutch drum basket with starter ring gear and steel & fiber clutch plates with pressure plate assembly. Front compensator sprocket assembly includes all parts necessary for installation, including sprocket nut. Big Twin 5 speed Softail models and all pre 1985 FLH, FX 4 speeds require 82 link primary chains. 1980-on FLT, FXR 5 speeds require 76 link primary chains.

82 Links Year
53083 1985-90



FXST 5 Speed Assembled Transmission 91-99

All numbers are stock ratio and are machined for electronic speedometer unit. Each transmission includes a 32T final drive pulley.

PCP Finish
58081 Natural with chrome 1991-99
58082 Black with chrome 1991-99
58086 Polished 1991-99



Four Point Ball Bearings for 5 Spd Trans Trap Doors

Four point bearings contact the race in four locations, not just two, as with standard ball bearings. The resulting radial load capacity is 1.5-1.7 times greater than that of a standard ball bearing.

15752 1999-on BT



Jims Chrome Billet Transmission Top Cover

Billet aluminum transmission top cover comes with gasket and chrome allen screws. For use on 1998-99 FLH, Softail and 6 speed models. Replaces 34468-98. Will fit 1987-97 FLH and FXST models when using 33902-98 switch and 33320-98 shifter drum.

31289

Trans to Motor Mount Kit TC-88

Fits Twin Cam 88, Dyna and FLT 1999-on.

9934



Big Twin 5 Speed

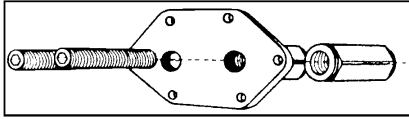

5-Speed Kicker Installation Tool

Save time when installing 5-speed kicker conversion units, in that the complete trans does not have to be dismantled. Mainshaft & clutch pak can remain in place. Reduces labour time from 6 to 3 hours.

26021



Chrome Cable End Covers

These chrome accessories cover the fitting on speedo, tach and clutch cables. Sold each.

Clutch Cable Cover

- 44020** Upper, all 1982-on
- 44021** Lower, XL 1986-on
- 44022** Lower, FXR 1987-94
- 44023** Lower, FXST, Dyna, FLT 1987-on

Speedo/Tach Cable Cover

- 44024** Upper, 12mm cable nuts
- 44026** Lower, all front wheel drive speedo cable only



BT 5 Spd Chrome End Covers

Offered in smooth and button head style. Outer socket head screw holds cover in place. Fits 1987-on models.

- 45025** Button head
- 45026** Smooth



Slim Profile 5/6 Speed Kick Start Kit

Pushrod modification may be required. Order kick arm and pedal separately.

21642

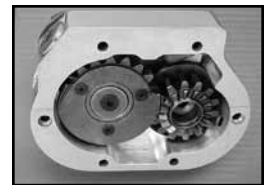

Transmission Dip Sticks

Big Twin, chrome plated, dipsticks have allen style heads, that allow for checking of fluid level without removing cap.

PCP Model

- 77008** 4 Speed 1936-64
- 77003** 5 Speed 1984-87

BT 5-Speed Parts



Chrome 5-Speed Covers (Clutch Release)

Order Screw Kits separately.

PCP Year

45507	1980-86 all (37104-84)
45508	1987-06 FXST, 1987-98 FLHR, FLT, Dyna (37105-87A)
45510	1987-94 FXR (37109-87A)
45555	2000-06 FXST-FXD USA
45509	2000-06 FXST-FXD (37105-99)

5-Speed Transmission Chrome Screw Kits, Side Cover

PCP Year Type

1768	1980-86	Acorn
2894	1980-86	Cap
8908	1980-86	Allen
8909	1987-on	Allen
8912	1987-06	Acorn
8913	1987-06	Cap



5 Speed Transmission Top Cover (No Screws)

Smooth style, chromed transmission top cover for all 1982-on 5 speed BT Evo models.

4340	1982-86
45511	1987-99 (not for Dyna models) (34468-86A)

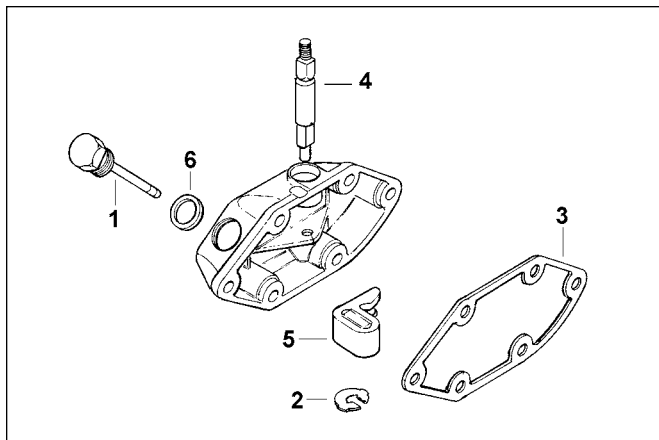

Big Twin Clutch Release 1980-86

Quality release parts for all Big Twin's 1980-86 5 speeds.

PCP Fits

1	2865	Chrome transmission dipstick
	5393	As above, cap style
2	11013	Retaining ring (11019) (10 pk)
3	79358	James cover gasket (36801-79) (10 pk)
4	36127	Clutch release shaft (37083-80)
5	36126	Clutch release finger (37084-79)
6	79362	Dipstick washer (37091-80) (10 pk)



Chrome Hex Dipstick FXST 1987-on
59131

5-Speed Transmission Chrome Screw Kits

PCP	Model	Type
8905	FX, FL 1980-86 (4-speed)	Allen
8906	FX, XL 1987	Allen
8910	1987	Acorn
8911	1987	Cap
8907	FXR, FLT, FXST 1988-97	Allen
9789	Dyna 1991-on	Allen
9785	Dyna 1991-on	Acorn
8921	BT 1988-on	Acorn
8922	BT 1988-on	Cap
9952	FXST, FLT 1998-on	Allen
9951	FXST, FLT 1998-on	Acorn



5-Speed Clutch Release Lever Set

Chrome plated clutch release lever set for all 5-speeds 1980-86. This kit replaces the 4 separate OEM clutch release arms used since 1980. Replaces the stock release arm and cable bracket with a stronger forged release arm and die cast tranny top cable bracket.

PCP Description

2409	Set (37085-80, 37094-82, 37096-83 & 37096-85)
36126	Release finger (37084-79)
11013	Shaft snap ring (11019) (10 pk)
36127	Finger shaft (37083-80A)
18709	Bushing (37102-84)

Trans Covers



Chrome FXST Trans Top

64809 FXST 1998-99, Touring 1998-00 USA (34468-98A)
64810 FXST 2000-06, FLT 2001-06 (34541-00)



Chrome Trans End Cover FXST, Dyna, Touring

PCP Application
45555 T/L 2000-06 FXST, 1999-05 Dyna, 1999-06 Touring
45509 Preston, as above (37105-99)



Chrome Dyna Trans Top

64811 1999-00 (34469-99B)
64822 2001-05 (34469-01)
64834 2006-on Dyna, 2007-on Softail and Touring (34469-06)



Chrome BT Transmission Dress Trim

Fully covers the end cover and inner door.
PCP Application
59128 2000-06
59129 FXST 1987-99
59130 FLT-FXR 1987-99



Jims Billet Clutch End Release Cover

Precision machined billet, chrome clutch release end cover is designed to reduce the amount of flex force when using either stock or a high pressure clutch spring. Includes gasket and screws for use on all 5 speed models. May be used with 6 speeds by using different hardware. Fits 1987-06 except FXR with mid controls.
31288

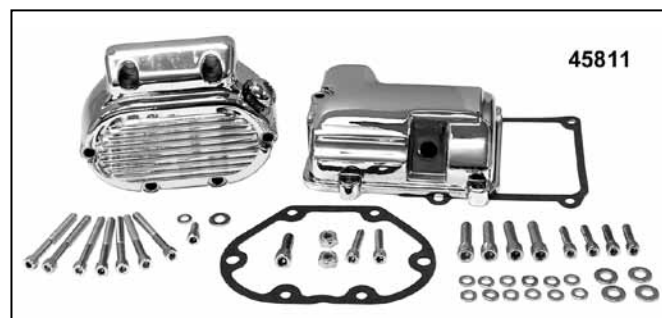

BT 5 Speed Chrome Trans Side & Top Covers

Chrome cover set includes chrome allen screws and a chrome allen dispstick.

PCP Application
45810 FXST, FLST 1987-99
45811 FXR 1987-94
45841 FXST 2000-06
45836 FXD 1999-00
45842 FXD 2001-05

Transmission Covers



T/L Engine to Transmission Cover 2002-06

Stylish chrome cover features a logo and a textured recessed area that allows easy access to the transmission dipstick.

This cover installs between the transmission and gearcase to hide unsightly oil lines on 2002-06 Touring models. Does not fit models equipped with hydraulic clutch or 6 speed transmission.

64307 66096-02



45402

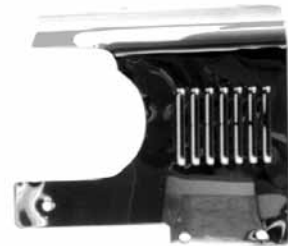

45403

Chrome Transmission Side/Oil Pump Cover

Fits all Softail models 1986-91. Available in plain or louvered styles. All mounting hardware included.

45402 Plain

45403 Louvered



FLT Engine To Transmission Interface Cover

Chrome plated steel cover hides the oil lines and cleans up the area between the motor and transmission without hindering removal of the dipstick.

64220 1999-01 Touring (not w/hydraulic clutch) (66003-99)



FXST Chrome Engine/Transmission Cover

Completely cover the space between the engine and transmission on 2000-06.

45431



Chrome Ribbed Transmission/Oil Pump Cover

Features ribbed pattern that matches transmission cover. Allows normal check of oil without removal.

PCP Fit

45424 1987-99 Softail (not FLSTS) (66395-92)

64200 1987-98 FLT 1340 models (66088-96)



FLT Chrome Engine/Transmission Cover

Completely covers oil lines in the space between the engine and transmission. Allows easy removal of dipstick.

45432 1999-2001 FLT

Transmission Cover FLT, FLHT 1984-86

Adds a distinguished look to your bike. Covers transmission and oil pump. Mounting hardware included.

3159 1984 & 1985

3161 1986 only

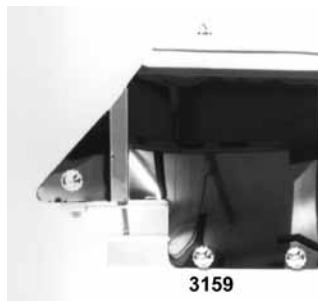

3159

Jim's 5 Speed

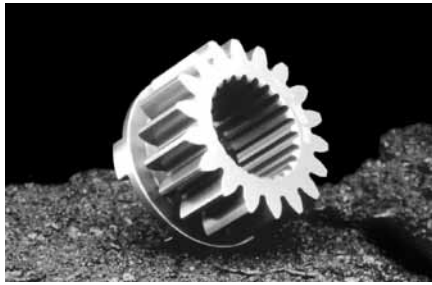

31316

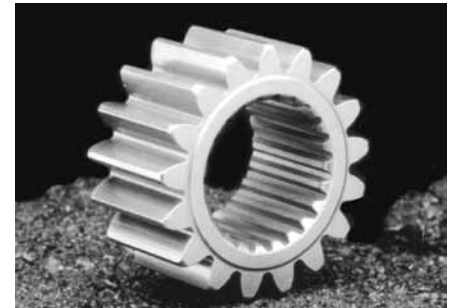
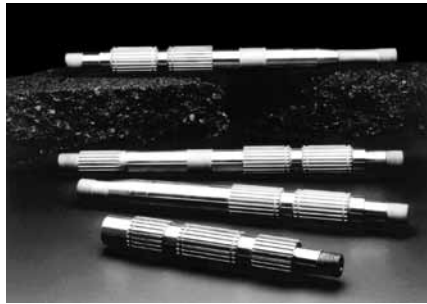

31321



31319



31317

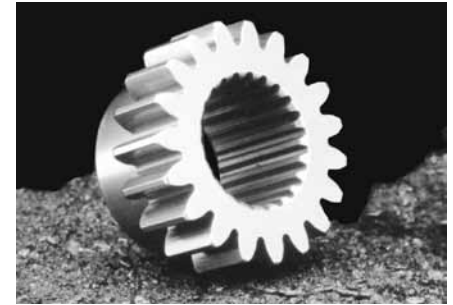

31320

Jim's BT 5 Speed Transmission Parts 1980-06

Jim's Machining uses aerospace quality steel. These precision parts are made by the same "A Cut Above" team that produces exceptional motor parts, shafts and bushings. Fully interchangeable with OEM parts.

PCP	Jims	Use
31316	35025-79B	1st Gear mainshaft, mate with 35622-79B
31319	35026-79C	2nd Gear mainshaft, 3rd countershaft, mate with 35027-79B
31322	35027-79B	3rd Gear mainshaft, 2nd gear countershaft (use 2 per transmission), mate with 35026-79A
31323	35028-79B	4th Gear mainshaft, mate with 35025-79B

Main Drive Gear

31324	35029-85A	1985-90 Main (5th) drive gear, mate with 35626-79B. Bearing and seal installed, requires a mainshaft with a bearing diameter of 1.000"
31325	35029-91A	1991-06 Main (5th) drive gear, mate with 35626-79B. Bearing and seal installed, requires a mainshaft with a bearing diameter of .9845" (use this gear with mainshaft 35042-91 for the 1990 model year)

Mainshafts

31327	35042-85	1985-89 Mainshaft, bearing diameter 1.000"
31328	35042-91	1991-06 Mainshaft, bearing diameter .9845" (use this mainshaft with a gear 35029-91A for the 1990 year model)
31329	35632-79	1979-06 Countershaft
31317	35622-79C	1st Gear countershaft, mate with 35025-79B.
31320	35625-79B	4th Gear countershaft, mate with 35028-79B
31321	35626-79B	5th Gear countershaft, mate with 35028-79, 35029-85A, 35029-91A

Close Ratio Gear Set (2.94:1) 1980-06

31318	2220	1st Gear close ratio set, makes 1st gear higher for lighter bikes and high performance motors. More MPH in 1st gear.
-------	------	--



31318



31322



31323



31324

Jims 5 Speed



Complete 5 Speed Big Twin Gear Sets

Gear sets for 5 speed transmissions includes all gears and shafts. Available with stock or close ratio first gears. These are the same precision gears used in JIMS complete transmissions and super kits.

Standard Ratio	Close Ratio	Description
31332	31333	1985-89
31334	31335	1990-06

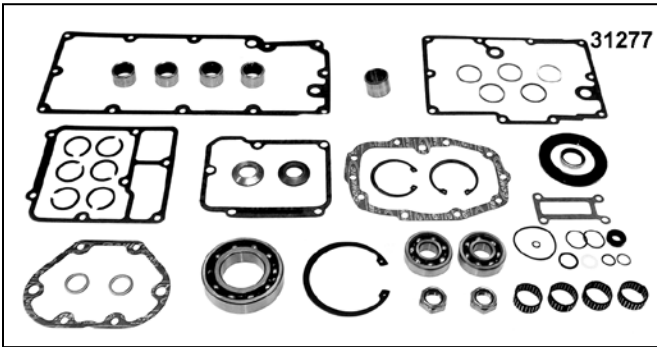

Jims "Timesaver" Master Kits

BT 5 speed Jims transmission parts plus James gaskets.

31275	BT L1984-90
31276	BT 1991-98
31277	BT 1999-06

Jims 5 Speed BT Trans Shift Pawl Assembly

This kit includes plate (35068-79), spring (34087-79), pawl plate (34086-79), shifter shaft (34084-86), spring (34083-79), pin (34082-79), washer (6016) and retaining ring (11016).

31046 Fits 1979-00 FL, 1982-94 and 1999 FXR, 1991-00 FXD, and 1986-99 FXST



Jims Early to Late 5 Speed Shifter Upgrade Kit

This is a simple upgrade kit to install on all early BT 5 speed 1980-99 FXST and 1980-2000 FL and Dyna. Make your early model shift smooth and positive with the latest in 5 speed technology. Kit includes a Jims shift drum and lever assembly which has a built-in anti-overshift feature. Kits come with late model pillow block, all necessary hardware, and a case shifter shaft sleeve bushing. For installation of the shifter sleeve, order Jims #1664 tool separately.

31347



Jims 5 Speed BT Polished Trap Door

31395 (Jims 2347-7)



Jims 5 Speed Mega Nut

The mega nut locks loose pulley nuts using a built-in lock plate. The mega nut can also be secured in several additional places by an easy drilling and tapping operation. Use Jims tool # 94660-37A to tighten nut. Mega nut will work with all belt drive pulleys, H-D or aftermarket, if drilling and tapping is performed. For use on BT and XL 1993-on with belt drive.

31022



Jims Solid Billet Left Pillow Block

Replaces 33326-79A for use on 1979-2000 FL, 1982-94 FXR, 1999 FXR, 1991-2000 FXD, 1986-99 FXST. Use for extreme shifting. If you are building an automatic 5 speed transmission or have back cut gears for super quick shifting, this pillow block offers several times more strength than stock units. Will also work on 6 speeds.

31045

Jims 6 Speed

58030



Jims 6-Speed Transmissions

Jims offers USA made 6 speed transmission with precision cut gears. Using a 6th gear can reduce engine RPM by about 500 RPM's. All gears are standard width for performance and strength, with first gear being close ratio 2.94, and the last four being the same ratio as a stock 5 speed. 6th gear goes to .086:01 overdrive.

Jim's complete transmissions are on a "Special Order only basis" and are not a stocked item

Jims 6-Speed Precision-Cut Gears

JIMS Precision Cut 6 speed transmissions include chromed billet covers, trap door and are shipped complete with bottled transmission oil and instructions. Feature a Factory Direct 6 year or 60,000 miles warranty.

Application	PCP #	1st Gear Ratio	Case	Case Finish	Trap Door
Softail 1990-99*	58028	Close Ratio	Jims	Plain Aluminum	All include Jims Chrome trap door #7075T
Softail 1990-99*	58029	Close Ratio	Jims	Black Wrinkle	
Softail 1990-99*	58030	Close Ratio	Jims	Polished Aluminum	
FXR 1990-94 & 1999	58031	Close Ratio	Delkron	Plain Aluminum	
FXR 1990-94 & 1999	58032	Close Ratio	Delkron	Polished Aluminum	
Softail 2000-06	58033	Close Ratio	H.D.	Plain Aluminum	
Softail 2000-06	58034	Close Ratio	H.D.	Black Wrinkle	

*Note: Not for models with mid-controls



Jims Chrome Transmission Shift Lever

Replaces 33715-85 for use all BT 5 speeds, 1985-96 and aftermarket 6 speeds, 4/5 speeds, and 4/5/6 speed transmissions.

31348



Jims Chrome Transmission Shift Lever

Replaces 33849-79 for use all BT 1997-06 5 speeds or aftermarket 6 speeds.

31349



Jims Complete Transmission Rebuild Kits

Convenient, time-saving kits come with the necessary gaskets, seals, locks and bearings to completely rebuild a transmission.

PCP Cruise Drive (Late 6 speed Trans)

31278 2007-on FLH
31279 2006-on FXD
31280 2007-on FXST

PCP Screamin' Eagle 6 Speed Trans

31284 1990-06 FLH
31285 1991-05 FXD
31286 1990-06 FXST

Big Twin 6 Speed



RSD 6 Speed Trans Hydraulic Handle 1991-99
59553

S&S 6 Speed Transmission

S&S offers complete 6 speed transmissions in natural, black powdercoat and polished finishes. Complete transmissions fit 1991-99 Softail models. Note: FLT owners will need oil filler spacer kit for additional clearance between the S&S transmission trap door, speed sensor, and the engine oil filler neck.

Complete Transmissions

Transmission and cassettes feature helical gears and are dog-less for quiet operation and smooth shifting. Supplied with an ultra light 34T front pulley and stock rear pulley for a final ratio of 1:1.

PCP	Finish
561130	Natural
561131	Black powdercoat
561132	Polished
561292	Oil filler spacer kit



BT 6 Speed Trans Assembly Softails 1991-99

This complete transmission assembly will reduce vibration at highway speed and improve fuel mileage. At 75mph the 0.86:1 overdrive ratio will produce a 475 RPM reduction when shifting from 5th gear. A 2.94:1 close ratio first gear will add approximately 5mph of useable 1st gear. The 2nd, 3rd, and 4th gear ratios are the same as OEM. Additional features of this transmission include a CNC machined, billet aluminum access door, chrome-moly full width gears for maximum torque applications, back cut dogs, 32T steel pulley, chrome plated top cover, side cover and shift rod lever. Also included are a cast finish trans case, provision for electronic speedo sending unit, clutch release pushrods and a Statement of Origin.

- 58078** Natural and Chrome finish (33005-99)
 - 58079** Polished and chrome
 - 58080** Black wrinkle and chrome finish
- Accepts 1996-on speedometer sensor PCP# 29500.

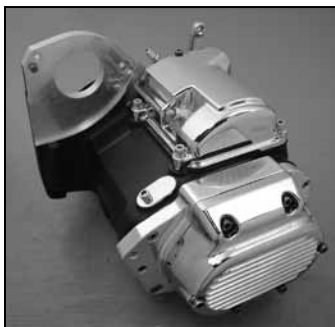

XL Sprocket Covers



Chrome XL Transmission Sprocket Cover

These chrome covers fit XL 2004-on models

- 64281** Topline (34932-04)
- 45496** Preston as above



XL Chrome Cover Screws

- Acorn **5502**
- Allen **9750** 1986-03 883/1100



Countershaft Washers for XL 1986-90

Washers are sold in packs of five for each size or as a set of 1 of each size.

- | PCP | Item |
|--------------|-----------------|
| 11650 | Set of 6. |
| 11644 | .030 (35865-86) |
| 11645 | .035 (35864-86) |
| 11646 | .040 (35863-86) |
| 11647 | .045 (35862-86) |
| 11648 | .050 (35861-86) |
| 11649 | .055 (35860-86) |



3068



45526

Sportster 1981-90

Die-cast OEM type quality covers.

- | PCP | Item |
|--------------|-------------------------------|
| 45525 | Polished 1981-90 (34911-81) |
| 45526 | Chrome 1981-90 (34911-81) |
| 3069 | Polish 1986-90 (34911-81A) |
| 3068 | Chrome 1986-90 (34911-81A) |
| 10824 | Stud 1986-90 (24752-86) |
| 10908 | Pivot stud 1980-90 (42441-80) |
| 27013 | Bracket 1983-90 (34909-83) |



45530

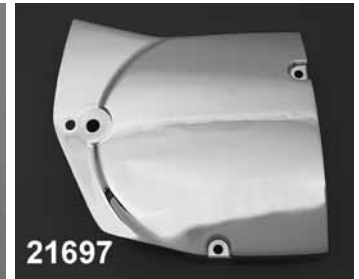

21697

Sportster 1991-on Belt/Chain

Fits STD, Hugger and 1200. Not C or S.

- | PCP | Item |
|--------------|-----------------------------------|
| 21696 | Polished cover 2004-on (34932-04) |
| 21697 | Chrome cover 2004-on (34932-04) |
| 45530 | Polished cover 1991-03 (34911-91) |
| 45531 | Chrome cover 1991-03 (34911-91) |
| 10909 | Pivot stud (42441-90) |
| 27014 | Bracket (34909-90) |



45415



45427

XL Chrome Sprocket Cover Trim 1986-03

These covers fit over the kicker cover above.

- 45415** 1986-90
- 45427** 1996-03 (34939-98) STD, Hugger, 1200

Andrews XL 5 Speed

XL Gears 5 Speed EV

The 5 speed XL gear box is a great way to travel especially if you're used to only 4 speeds. For high performance applications, our 2.61 close ratio first gears will be a welcome option. In addition to close ratio first gears, Andrews Products makes replacement parts for 2nd, 3rd, 4th, 5th gears and both transmission shafts.

As with the close 1st gears, all 5 speed gears are made from high nickel alloy, heat treated and shot peened to give maximum durability and strength. Also, where applicable, lead-in ramps have been machined into most gears to improve shifting and reduce wear on drive dogs and drive slots.

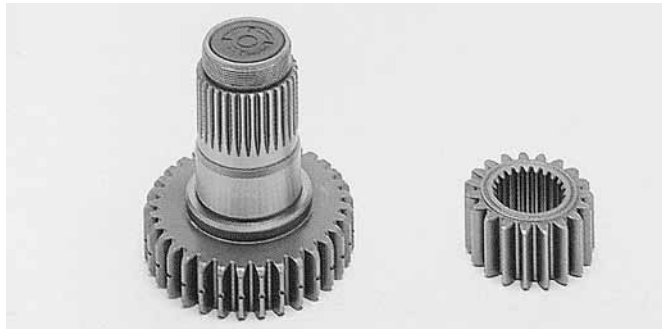

Stock Main Drive Gears

Made from high nickel gear steel for maximum strength. Main drive gear also has lead-in ramps for quick positive shifting.

- 299105** Main drive gear (35034-89)
299155 Counter drive gear (35633-89)



Transmission Shafts

Replacement transmission shafts are made from high nickel steel with aircraft quality heat treatments.

- 299180** Mainshaft (35640-89)
299170 Countershaft (35641-89)

Internal transmission ratios are listed below.

Gear	Close First	% Change	Stock	%Change
1st	2.605	22%	2.779	27%
2nd	2.026	27%	2.026	27%
3rd	1.489	18%	1.489	18%
4th	1.216	18%	1.216	18%
5th	1.000		1.000	

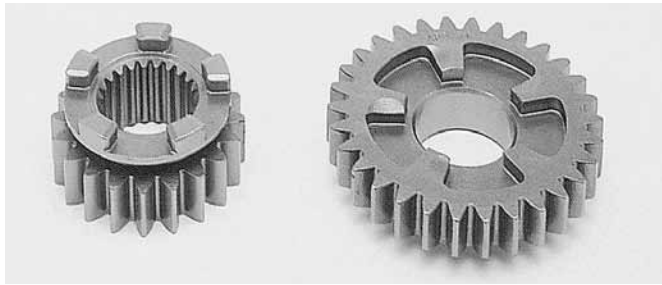

2.61 Close Ratio 1st Gear Set

2.61 1st Gears provide true close ratio shifting into 2nd. Plus 7 mph of usable 1st gear. (2 pieces)
299110

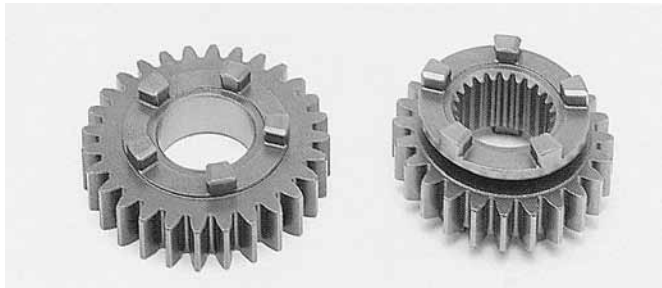

Stock 2nd and 3rd Gears

High nickel steel parts with lead-in ramps for maximum strength. Main drive gear also has lead-in ramps for quick positive shifting. Drive edges shot peened for super wear resistance.

- 299102** 2nd Main / 3rd counter (35771-89)
299103 3rd Main / 2nd counter (35772-89)

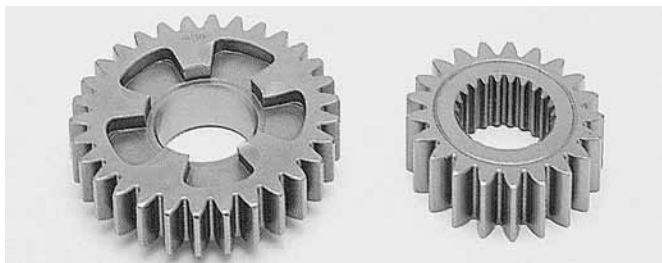

Stock 4th Gears

Made from high nickel steel material with shot peened surfaces. Main gear also has lead-in ramps.

- 299104** 4th Main gear (35773-89)
299144 4th Counter gear (35775-89)

Andrews Sportster Gears (EV 5 Speed)

Ratio "S" Gear Set

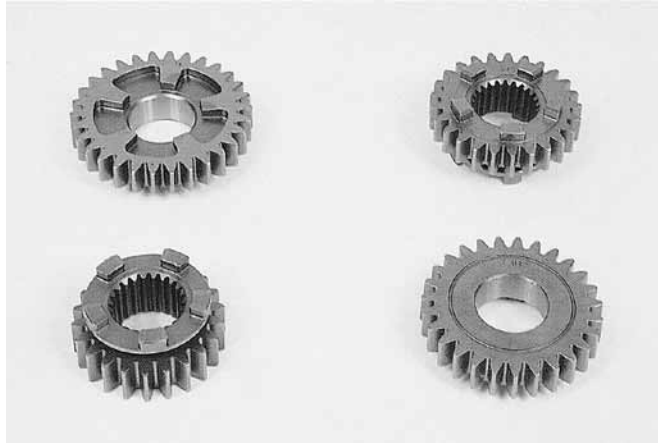

Medium Close Ratio 1st and 2nd.

For drags and modified street bikes needing closer ratio shifts through 1st and 2nd gear, ratio "S" gear sets will be a distinct advantage. Each set includes a new 1st and a new 2nd gear with the ratios listed (see chart at the bottom of this page). "S" gears will fit all 5 speed Sportster and Buell gearboxes with no modifications. All "S" gears are made from aircraft quality, high nickel alloy steel and then shot peened for maximum durability.

299816 (2 gears) 2.368 1st gears

299724 (2 gears) 1.876 2nd gears

Ratio "Y" Gear Set

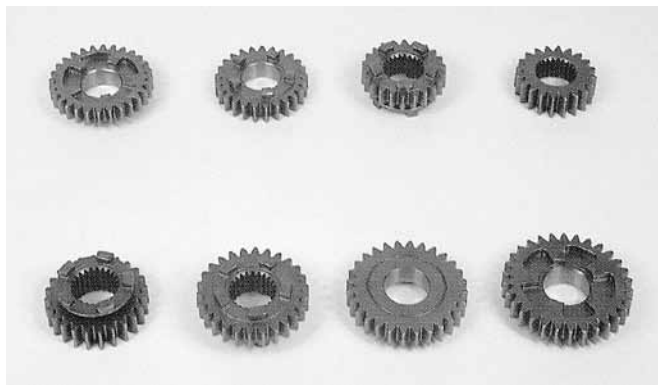

Super Close Ratio 1st, 2nd, 3rd, 4th

For drags and road racing. Applications on longer length tracks need very close ratio shifting through all 5 gears, "Y" gear sets will put more useable torque where it belongs-at high RPMs. Each set includes new 1st through 4th gears with the ratios listed (see table below). "Y" gears will fit all 5 speed Sportster and Buell gear boxes with no modifications. All "Y" gears are made from aircraft quality, high nickel alloy steel and then shot peened for maximum durability.

299717 (2 gears) 2.026 1st gears

299727 (2 gears) 1.670 2nd gears

299737 (2 gears) 1.364 3rd gears

299747 (2 gears) 1.158 4th gears

Ratio Comparison

Gear	Stock	Change	Close	Change	Ratio S	Change	Ratio Y	Change
1st	2.779	27%	2.605*	22%	2.368**	21%	2.026***	17%
2nd	2.026	27%	2.026	27%	1.876	21%	1.670	18%
3rd	1.489	18%	1.489	18%	1.489	18%	1.364	15%
4th	1.216	18%	1.216	18%	1.216	18%	1.158	14%
5th	1.000		1.000		1.000		1.000	

* This ratio changes only 1st gears

** Ratio "S" changes 1st and 2nd gears (4 piece set)

*** Ratio "Y" changes 1st, 2nd, 3rd, 4th (8 piece set)

XL 5 Speed

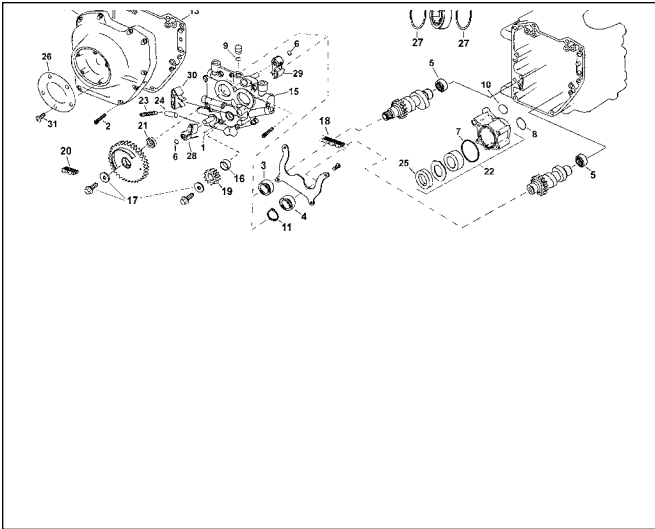

XL 5 Speed Transmission Gears 1991-on

#	PCP	OEM	Description
1	18000	6003	Thrust washer 91-97(5 pk)
2	15600	8876A	Bearing
3	15605	8977	Bearing, closed end
4	15707	8996A	Ball bearing
5	11031	11067	Retaining ring (10 pk)
6	11040	11161	Retaining ring (ea)
7	14528	11165	Quad seal (10 pk)
	79039	11165	James quad seal (10pk)
8	14098	12030	Oil seal 1991-on (5pk)
	79069	12030	James oil seal (5 pk)
9	14021	12050	Oil seal 1991-94 (ea)
	79080	12050	James oil seal (ea) 1991-94
	14076	12067A	Oil seal 1995-on (5 pack)
	79508	12067A	as above James (each)
10	11538	33334-85	Spacer 1991-94
	18006	33344-94	As above 1995-*
11	45530	34911-91A	Sprocket cover 1991-03
12	11089	35020-89	Retainer, countershaft (5 pk)
13	18004	35022-89A	Spacer
14	36201	35034-89A	Gear assembly w/ #8 & 15, fifth mainshaft 1991-95
15	15626	35051-89A	Needle Bearing
16	18005	35063-89	Spacer (5 pk)
17	12602	35211-91A	Sprocket nut
18	36202	35633-89A	Gear, fifth countershaft 1991-95
19	36203	35640-89	Mainshaft
20	36204	35641-89	Countershaft
21	36205	35762-89A	Gear, first mainshaft
22	36206	35763-89A	Gear, first countershaft
23	36207	35771-89A	Gear, second mainshaft, third countershaft 1991-95
24	36208	35772-89A	Gear, third mainshaft, second countershaft 1991-95
25	36209	35773-89A	Gear, fourth mainshaft 1991-95
26	36210	35775-89A	Gear, fourth countershaft 1991-95
27	12603	37495-91	Nut, mainshaft 1991-on
28	5957		21T Sprocket STD Hugger 91-92
29	20501	37870-91	Spring washer 1991-on
30	65507	40202-91A	29T Sprocket kit (belt) 1200's
	65508	40285-91B	27T Sprocket kit (belt) 883 models
31	13741	40251-92A	Retention plate

Note: The gears listed above are not "High Contact" gears

Sportster 5 Speed Shifter 1991-on

#	PCP	OEM	Description
1	10103	601	Roll pin (10 pk)
2	11013	11019	Retaining ring (10 pk)
3	36154	33178-90	Shift drum plate
4	36155	33204-91	Shift drum plate
5	10145	33319-90	Roller (10 pk)
6	36156	33634-91	Shifter drum assembly
7	16053	33652-90	Detent roller (10 pk)
8	11107	33653-90	Retaining ring (10 pk)
9	36157	33655-90	Detent arm
10	36158	33656-90	Detent plate
11	36160	34142-89C	Shifter fork, first & second
12	36161	34144-89C	Shifter fork, third & fifth
13	36162	34147-89C	Shifter fork, fourth
14	24056	34486-90	Detent arm screw
	15736	35030-89	Bearing



XL Access Door 1991-on

#	PCP	OEM	Description
1	15708	8998	Bearing 1991-98
2	18713	9187	Bushing
3	18705	16573-83	Insert, access door (5 pk)
5	11108	35021-89	Retaining ring 1994-98
6	15736	35030-89	Bearing
7	11068	35038-89A	Retaining ring

XL 5 Speed

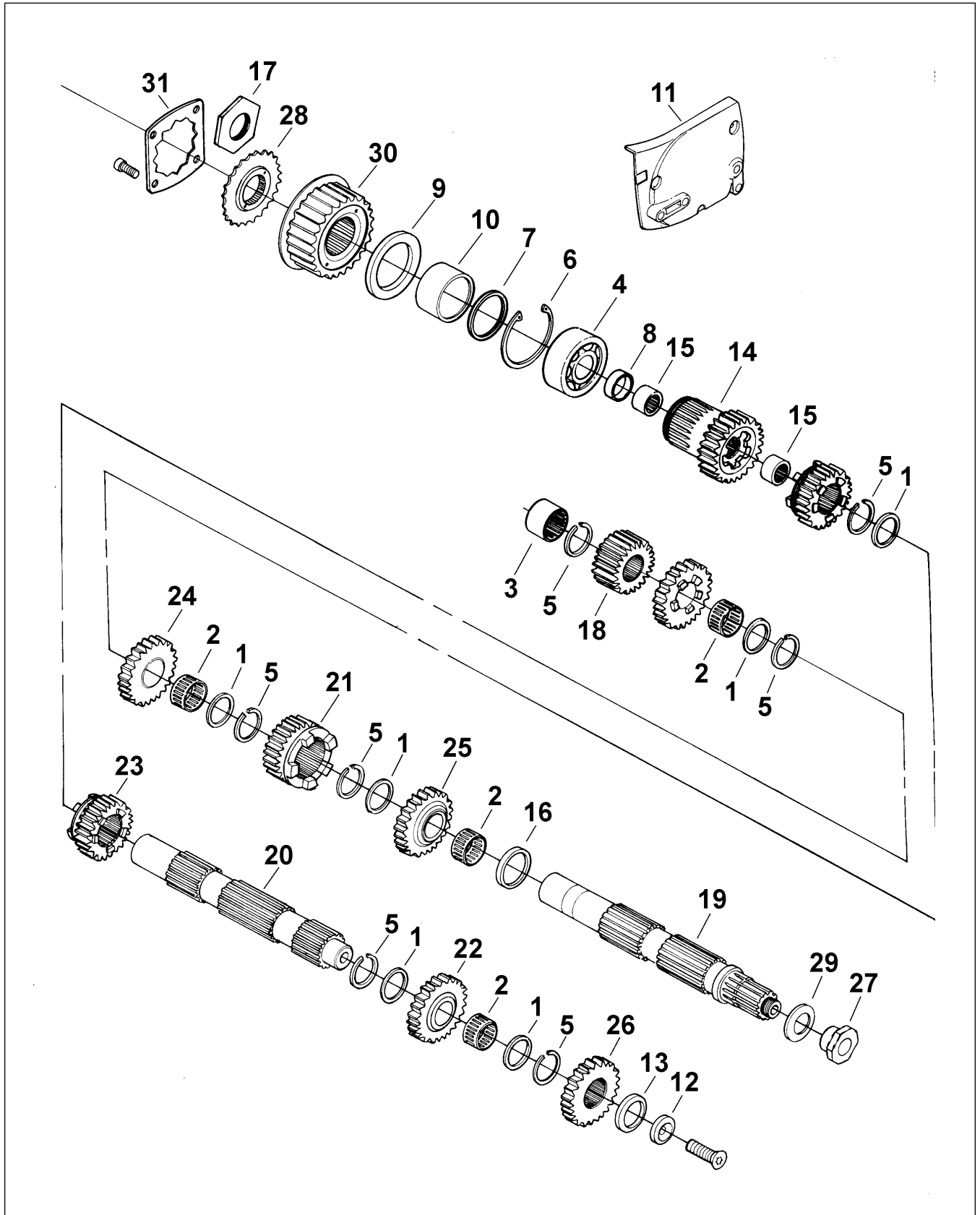

XL 4 Speed Shifter Parts

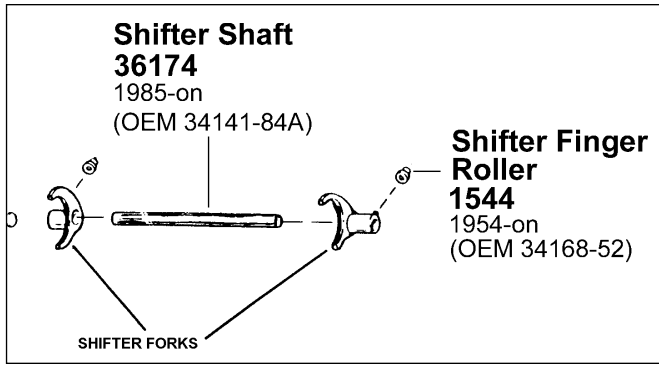

XL Shift Forks 1952-90 4 Speeds

One piece forged, heat treated and precision machined shift forks are available in steel or brass with standard or offset dimensions.

Brass	Steel	Size	OEM
37120	2069	STD	34291-52B
	37127	+ .005	
	37128	- .005	
37121	37131	+ .010	34297-84
37122	37132	- .010	34296-84
37123	2164	+ .020	34292-72
37124	2165	- .020	34293-72
37125		+ .030	
37126		- .030	
36174	Shifter shaft 1985-on (34141-84A)		
1544	Shifter finger roller 1954-on (34168-52)		

Complete XLH, XLCH 4 Speed Trans Gear Unit

Gear assembly unit includes all gears, main and counter shaft, shift forks and shaft assembled to trap door. Right side case races, roller, shims, bearings and shift selector must be ordered separately for the appropriate year. **Note:** Main and countershaft end play and trap door alignment with case must be established and adjusted before final assembly.

PCP	Application
36922	XLH, XLCH 1986-90



XL Gear Selector Shafts 1986-on

PCP # 36146 and 36147 are splined on shift lever end.

PCP	OEM	Application
36146	34628-86	1986-90
36147	34015-91	1991-02
36172	34014-02B	2003-05
36173	34014-06	2006-on
14010	12010	1986-on Oil seal
18570	40520-63	1979-on Bushing
79363	37101-84	1984-on Oil seal
18588	40574-06	2006-on Bushings



XLH-XLCH Transmission Trap Doors

All Trock pieces are reinforced.

PCP	Description
36168	1986-90 Door w/alternator, stock (34853-86)
36169	1991-94 Door w/alternator, stock (25238-90)
36170	1991-94 Door, Trock (25238-90)
18705	1991-on Insert, stock (16573-83) (5 pk)
10129	1957-on Dowel (pair) (24578-57)



XL 4 Speed Pawl Carrier 1952-90

Replaces OEM 34009-75A
37114